

T  
H  
E  
F  
A  
L  
K  
C  
O  
R  
P  
O  
R  
A  
T  
I  
O  
N

# True Torque™ Fluid Couplings

Protecting your system, enhancing component life,  
from beginning to end.



**FALK®**  
a good name in industry

# True Torque™ Fluid Couplings

## Economical soft starts, with smooth acceleration. Shock-load protection

From underground & overland belt conveyors to crusher and mixing applications, equipment professionals are constantly seeking better technology to protect critical production systems against the effects of damaging shock loads. And when it comes to eliminating sudden/jarring starts, or preventing system failure/deterioration due to overloads, nothing outperforms the system-saving capability of Falk True Torque fluid couplings.

- Proven reliability in demanding applications.
- No contacting surfaces to wear out ... virtually no maintenance.

**Providing the softest, smoothest start will maximize the life of your system components.**

As the smart alternative to expensive & complicated electronic solutions, Falk True Torque fluid couplings allow precise adjustment of startup characteristics in the field, simply by changing the fluid fill level via the easy access fill & drain holes.



- Unmatched, cushioned soft start flexibility, at an economical price point. Smooth acceleration.
- Mechanical overload protection.
- **NEW** sizes 2760HF & 2870HF offer higher capacity at higher speeds
- Increased starting torque available from standard NEMA B motors with a fluid coupling. This is a benefit not offered by electronic soft start solutions.

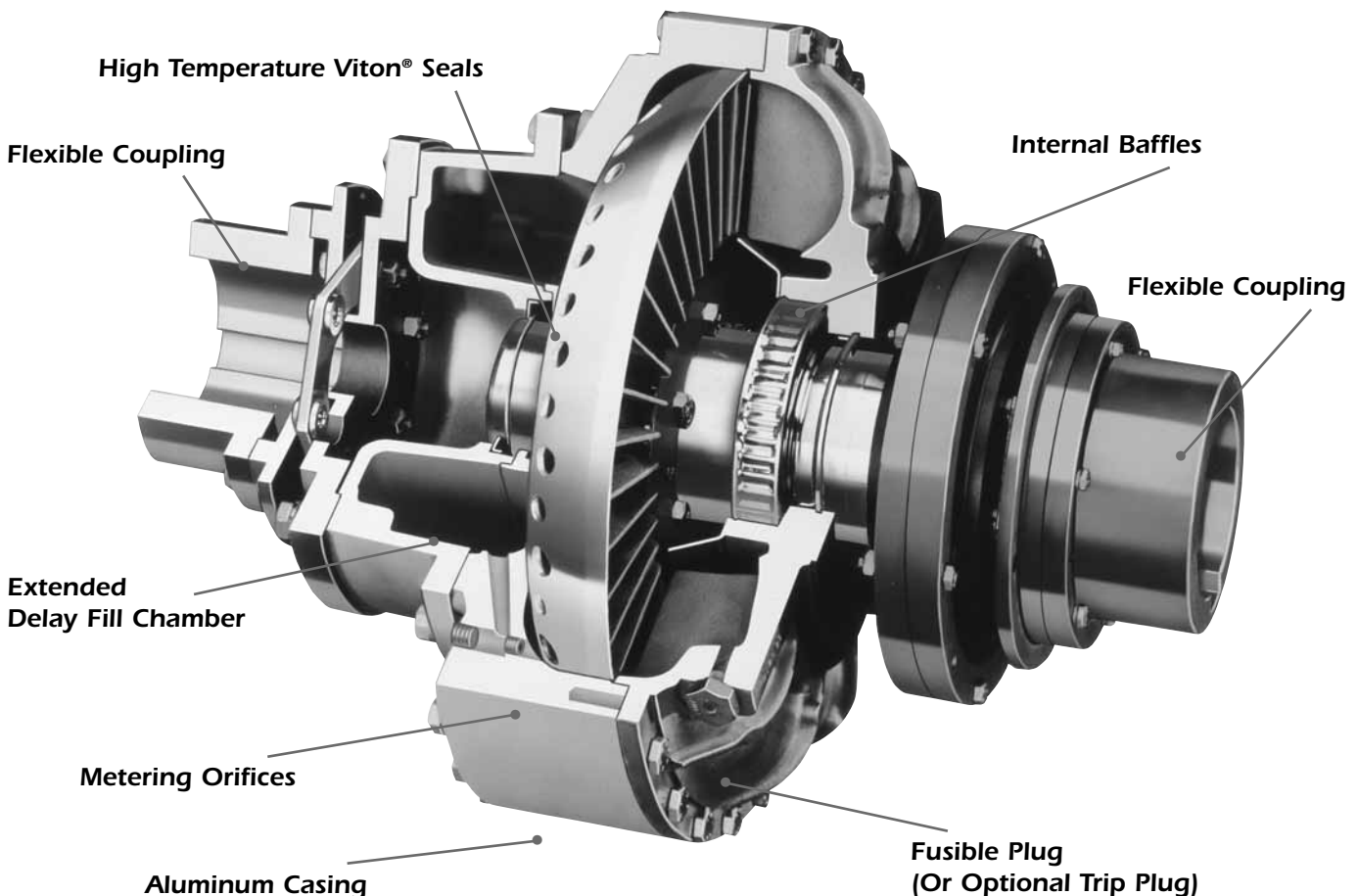

- **NEW** Longer starting profiles and softer starts
- For Sizes 1420HF & larger, adjustable metering orifices regulate the passage of fluid from the delay fill chamber into the working circuit, further softening the start.
- For sophisticated belt conveyors, consider Type HFDD. The extended delay fill chamber permits initial start factor as low as 40% of the full load torque, dramatically reducing shock & stretch to the belt at startup.

Use of the extended delay fill chamber (HFDD) is recommended for conveyors subjected to unloaded starts, those with concave sections, those with low inertia, or those with any combination of these conditions. Modest fill in the working circuit at startup minimizes belt liftoff, and assures unloaded & low inertia conveyors are not rapidly accelerated. Protection - regardless of load condition.

Torque applied to a belt conveyor starts at zero (point C) and gradually increases in magnitude as the coupling impeller accelerates to point D. When the output torque of the fluid coupling exceeds the breakaway starting torque of the belt conveyor (point D), the conveyor gradually & smoothly accelerates to full speed.

### Prevent jamming overloads that can cut short the life of your system.

True Torque fluid couplings safeguard your system against mechanical overload. Simple, straightforward protection when instantaneous jams are encountered.

- Two fusible plugs per coupling, are a standard feature, and prevent damage to the driven equipment and the motor.
- The proximity sensor cutout switch accessory, an extra charge option, prevents fluid discharge, and provides ability to reset cutouts in case of frequent overloads (see page 12).
- Another optional accessory, the easily replaceable thermal trip plug, is used in conjunction with a trip switch, also preventing fluid discharge (see page 12).

### Increase the starting torque available for hard starting conditions.

Over-sizing of electric motors for the purpose of increased starting torque can be avoided with a properly selected fluid coupling. A fluid coupling allows the motor to accelerate independently to full speed,

the driven load has been isolated by the fluid coupling. Once the motor is started, the fluid coupling gradually introduces the driven load. If the starting load is high, the breakdown torque (Point B) of the energized motor is now available for starting purposes.

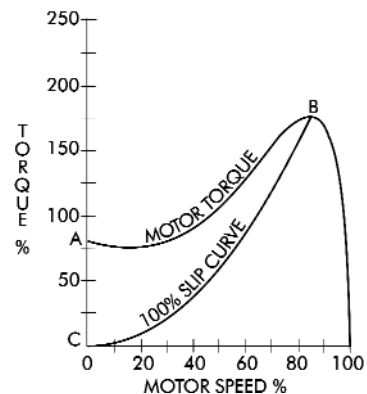

### Easily balance the load sharing between multiple drives.

Adjust the fill so each motor carries an equal burden.

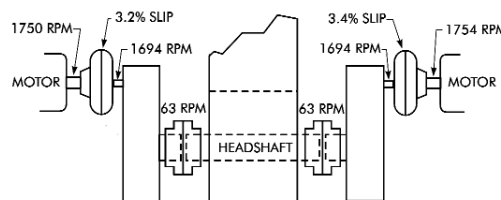

### HFDD Starting Profile

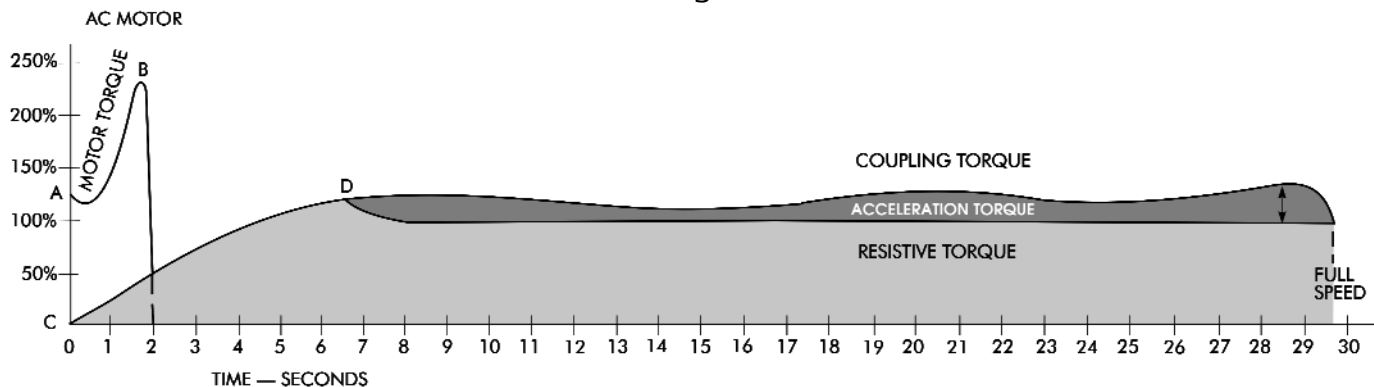

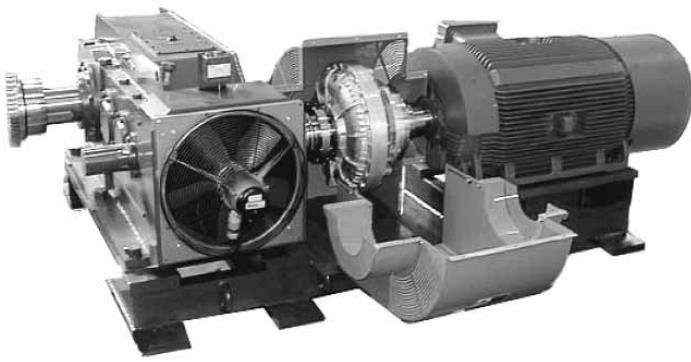

## Complete drive systems from Falk

But Falk's capability isn't limited to just selling a component, we sell drive systems incorporating the gear drives, couplings, backstops, brakes, guards & motors, all mounted on a bedplate, swing base or alignment free assembly.

Plus, our ready availability keeps you producing... even in the most remote places on Earth.

## Fluid Coupling Solutions to suit any need.

The gear coupling mounting arrangement (HF20) features economy, ready availability from stock components, and permits convenient drop-in/drop-out servicing.

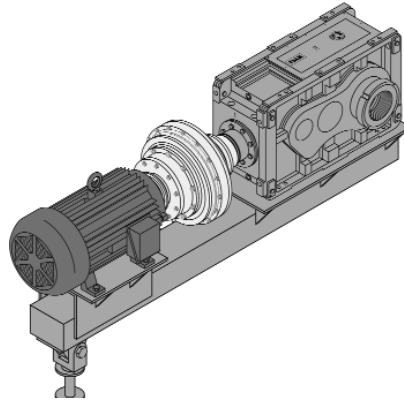
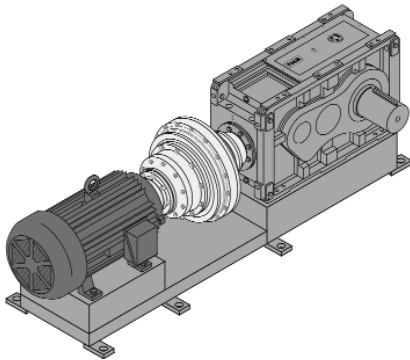

The disc coupling mounting arrangement (HF25) is non-lubricated, features drop-in/drop-out servicing, and permits high power at high rpm.

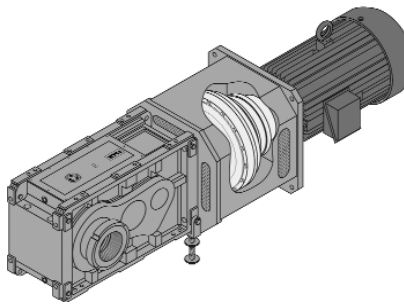

The elastomer coupling mounting arrangement (HF132) is non-lubricated, and is ideally suited for minimum shaft gap requirements.

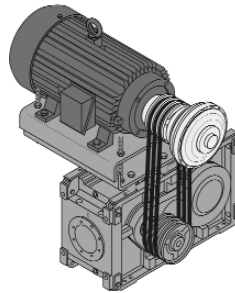

The sheave mounting arrangement (HF41) is designed for use with V-belt or synchronous belt connections.

**TRUE TORQUE™**  
**FALK FLUID COUPLINGS**

## Basic Types

The non-delay fill option (HFN/HFR) provides soft start, including a short delay (example: 5-10 seconds) in the acceleration of the load, and is a good choice when overload protection or increased starting torque is a primary requirement.

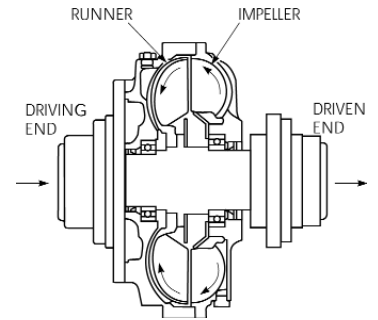

The delay fill option (HFD) provides a softer, more cushioned start, including longer delay (example: 10-20 seconds), ideal for heavily laden belt conveyors.

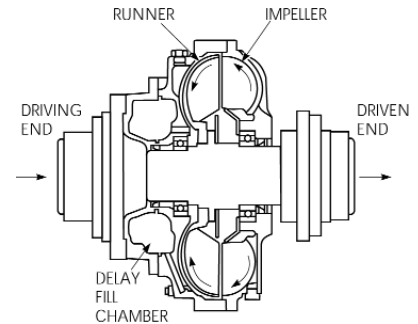

The extended delay fill option (HFDD) provides the softest, most cushioned start of empty, low inertia belt conveyors (example: 20-40 seconds).

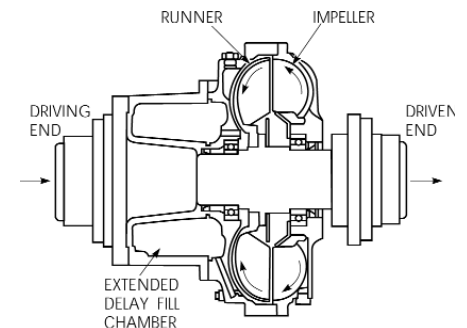

---

# Selection Guide 521-110 June 2004

## Table of Contents

Benefits of a Fluid Coupling . . . . .	6-7
Mounting Arrangements . . . . .	8
Basic Types . . . . .	9
Principles of Operation . . . . .	10-11
Accessories . . . . .	12-13
How to Select . . . . .	14
Fluid Coupling Identification . . . . .	15
Availability Table . . . . .	15
Quick Selection Tables . . . . .	16-21
HF20 Gear Coupling Mount . . . . .	22-23
HF31, 31-1, 32, & 32-1 Steelflex/Hollow Shaft Mount . . . . .	24-25
HF25 Disc Coupling Mount . . . . .	26
HF132 & 132-1 Tschan/Hollow Shaft Mount . . . . .	27
HF41 Sheave/Shaft Mount . . . . .	28-31
Engineering Data . . . . .	31
Recommended Fluids . . . . .	32

**Speed Variation of Multi-Speed Applications** – Fluid couplings offered in this selection guide are designed to operate on single speed applications, i.e. the motor driving the fluid coupling is started, accelerates to its base speed, and is not subject to speed variation about its base speed. The operating characteristics of a fluid coupling (a centrifugal device) are dependent on the speed of the coupling, and in particular, reduction in speed from those conditions identified in the selection tables will cause diminishing performance. All variable speed or multi-speed applications should be referred to Falk to determine whether a fluid coupling is suitable for the application.

**Warranty** — The warranty period for Fluid Couplings is 1.5 years from date of shipment. The description of what is covered by this warranty is found in Falk’s General Conditions & Terms/Standard Conditions of Sale.

## Basic Information

### Safety Notes

Install and operate Falk products in conformance with applicable local and national safety codes and per Falk installation manuals which are shipped with fluid couplings and are also available upon request. Suitable guards for rotating members may be purchased from Falk as optional accessories. Consult your local Falk district office for complete details.

**People Conveying Equipment** Selection of Falk products for applications whose primary purpose is the transportation of people is not approved. This includes such applications as freight or passenger elevators, escalators, man lift platforms, and ski tows and ski lifts.

If the primary purpose of the application is material conveyance and occasionally people are transported, the Falk warranty may remain in effect provided the design load conditions are not exceeded and certification to the appropriate safety codes and load conditions has been obtained by the system designer or end user from the appropriate enforcement authorities.

# Benefits of using a Falk fluid coupling

## Soft cushioned starts

Without the fluid coupling, the motor instantly transmits its locked rotor torque (starting torque) to the driven machine (point A at right). Then, it quickly reaches and applies the breakdown torque (point B). For common applications, locked rotor and breakdown torque often approximates 200% or more, of the motor nameplate rating.

Damage can result if the required break-away starting torque of the driven machine is significantly less, the machine will be abruptly accelerated to rated speed.

With a fluid coupling installed, however, the torque to the driven machine starts at zero (point C) and gradually increases as the coupling impeller accelerates to point D.

When the output torque of the fluid coupling exceeds the break-away starting torque of the driven machine (point D), the driven machinery gradually accelerates (right half of chart). As the machine comes up to rated speed, the slip of the fluid coupling decreases to (point E) and uniform power is transmitted at maximum efficiency.

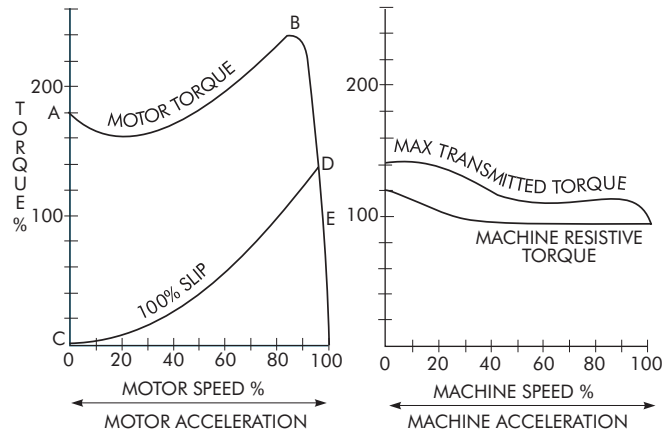

## Increased starting torque

With a fluid coupling, the breakdown torque of a standard NEMA B squirrel cage motor can be used to provide additional torque to start the machinery.

In this example of a high horsepower application, the NEMA B motor will initially exert only 80% of its rated torque (point A). Only if the motor can accelerate to 85% of its synchronous speed can it take advantage of its 175% breakdown torque (point B).

However, with a properly selected fluid coupling, the motor can start under no load (point C), and reach its breakdown torque in only a few shaft revolutions.

If a fluid coupling is not utilized, an oversized motor or a special high starting torque motor may be required. These solutions are costly, and introduce undesirable variables into the system. A properly selected and filled Falk fluid coupling can provide an initial starting torque ideally matched to the needs of the driven machine. Attainable initial starting torque values range from 40% of normal running load minimum, up to a maximum initial starting torque value that equals the full breakdown torque of the motor.

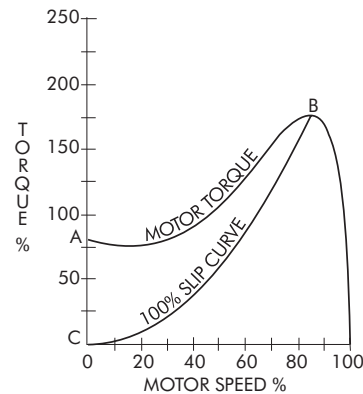

## Overload protection

When a machine jams, the life of individual components may be drastically reduced. Without overload protection, the stored energy of the machine is absorbed in the first second following the jam, increasing stresses on components to many times their normal running values.

The fluid coupling slip characteristics spreads the absorption of the impact over a period of time, reducing stress on the components and therefore, protecting your machinery.

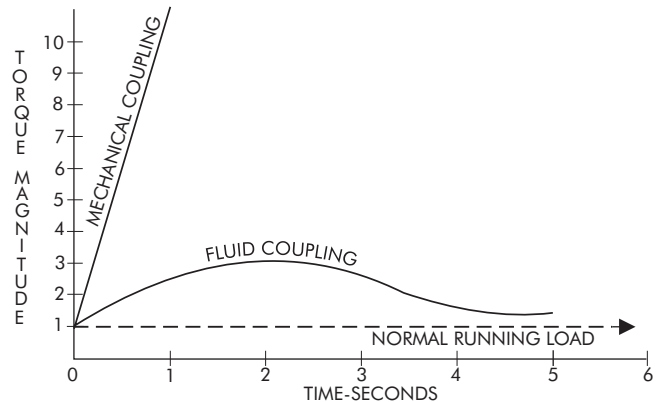

## Reduced current draw when starting

The electric current draw at startup is dramatically reduced when a fluid coupling is present. The motor starts without any meaningful load yet applied by the driven machinery (point A, Figure 1). In the absence of load, the motor quickly accelerates to approximately 90% of its full load speed (point B, Figure 1). The result is that low current draw (point C, Figure 1) is achieved within several shaft revolutions. At this point the inertia of the motor has been accelerated, and the application of load from the driven machine will not cause subsequent periods of high inrush current.

With a fluid coupling, the duration of high current draw is reduced substantially as shown in the shaded area of Figure 2. This results in electrical savings and extended service life of the motor.

## Accessories provide non-discharging protection against overload (Page 12)

If a jam occurs without a fluid coupling, the motor will stall, and draw over 500% of full load current (point A), and possibly burn out. Furthermore, mechanical impact forces of even greater magnitude can be generated which can damage the driven machine.

With a properly selected Falk fluid coupling, the motor speed will lug down only to the intersection of the motor torque and 100% slip curve of the fluid coupling (point B). Therefore, the current draw of the motor will only rise to point C. If the overload or blockage is removed, the drive will resume its normal torque and speed. If not removed, the coupling fluid temperature will rise, causing the fusible plug to melt. This disconnects the torque from the driven machine. In lieu of fusible plug, consider proximity sensor cutout switch, or non-discharging thermal trip plug and thermal trip switch. See page 12 for details.

## Load balancing for multiple drives

Loads can be easily balanced on multiple drive systems when fluid couplings are installed at each motor. Refer to the illustration at the right, two motors, each equipped with a fluid coupling. Load sharing between the two motors has been achieved by appropriately adding fluid to one coupling, or withdrawing fluid from the other coupling.

As an added benefit, motors on multiple drive systems can be individually started because of the ability of one coupling to temporarily operate at 100% slip. Starting one motor at a time provides extended and even softer starts on multiple drive conveyors. Since the motors are started as separate events, the system maximum inrush current will be approximately half the system maximum inrush current experienced when both motors are started simultaneously.

## Load dampening

Fluid coupling dampens shock and vibratory load to maximize equipment life.

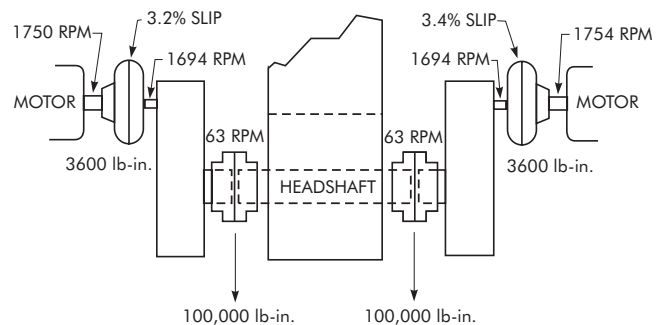
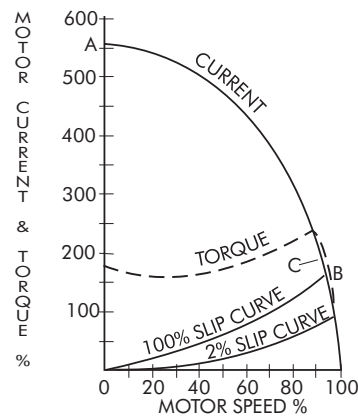
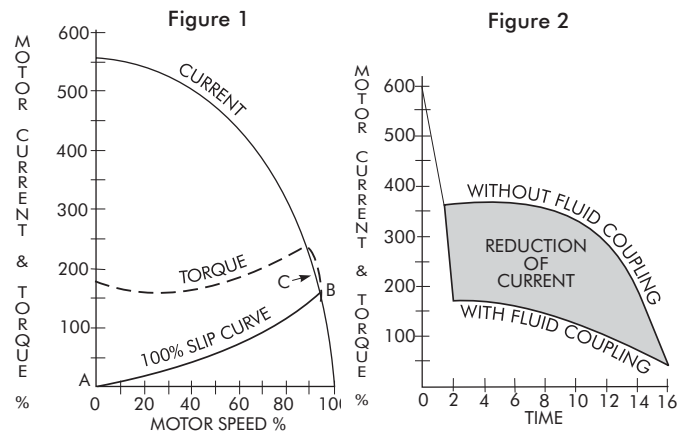

# Mounting Arrangements

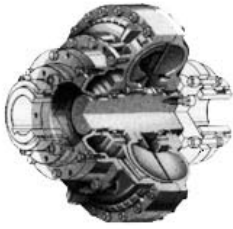

Pages 22-23

## Gear Coupling Mount

Type HF20 (Exposed Bolt)

- Most Economical
- Drop-in/drop-out servicing (no need to move connected equipment)
- Available Sizes 185-1660
- Readily shipped from stock components

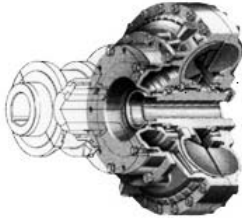

Pages 24-25

## Steelflex/Hollow Shaft Mount

Type HF31 (Setscrew Retention)

Type HF32 (Keeper Plate Retention)

- For limited shaft gaps/Steelflex grid coupling at driving end
- Hollow shaft bored to the order
- Type HF31/available Sizes 320-1480/secured to driven shaft with (2) setscrews/allow clearance for setscrew wrench
- Type HF32/available Sizes 320-1760 & 2760/secured to driven shaft with keeper plate & retention fastener/drill & tap driven shaft end for retention fastener
- Excellent performance @ high power & high rpm

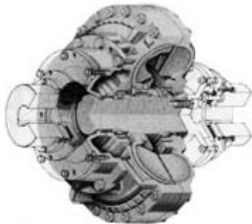

Page 26

## Disc Coupling Mount

Type HF25

- Non-lubricated, low maintenance, long life
- Drop-in/drop-out servicing (no need to move connected equipment)
- Available Sizes 370-2870
- Excellent performance @ high power & high rpm

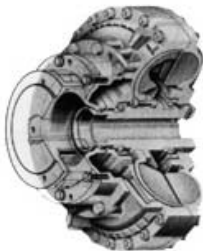

Page 27

## Tschan/Hollow Shaft Mount

Type HF132

- For minimum shaft gaps/Tschan elastomer coupling at driving end
- Non-lubricated, low maintenance
- Hollow shaft bored to the order
- Available Sizes 370-1760 & 2760/secured to driven shaft with keeper plate & retention fastener/drill & tap driven shaft end for retention fastener
- Excellent performance @ high power & high rpm

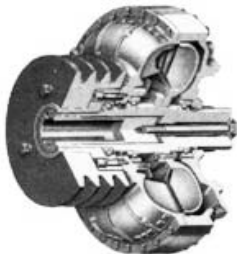

Pages 28-31

## Sheave/Hollow Shaft Mount

Type HF41

- For V-Belt connections
- Mounted on motor shaft
- Sizes 185-370/QD sheave by purchaser/standard hollow shaft collet with draw bolt by Falk
- Size 1420/special sheave by Falk/standard hollow shaft collet with draw bolt by Falk
- Sizes 1480-1584/special sheave by Falk/hollow shaft bored to the order/secured to motor shaft with keeper plate & retention fastener/drill & tap motor shaft end for retention fastener
- Follow manufacturer's recommendations when tensioning V-Belts



# Basic Types

## Non Delay Fill (HFN) and Inactive Delay Fill (HFR)

- Soft, cushioned start with a short delay in the acceleration of the load (Example: 5 seconds)
- Satisfactory soft start for many common applications
- Best choice for overload protection (Page 6)
- Good choice for increased starting torque (Page 6)
- All fluid remains in the working circuit
- HFR (plugged delay fill chamber) furnished when HFN not available

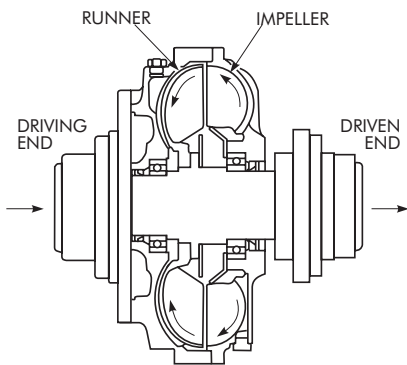

## Delay Fill (HFD)

- Softer, more cushioned start with longer delay in the acceleration of the load (Example: 12 seconds)
- Excellent choice for belt conveyors, and other applications calling for sophisticated soft start
- Incorporates delay fill chamber
- At start, the working circuit has reduced fill. Fluid from the delay chamber is metered into the working circuit during acceleration.
- Provides overload protection

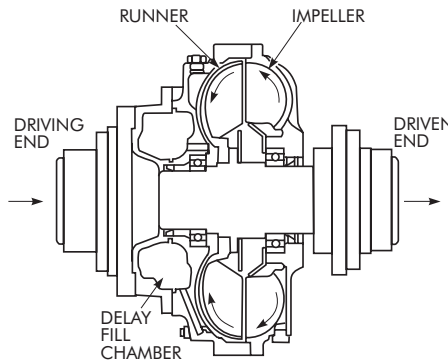

## Extended Delay Fill (HFDD)

- Softest, most cushioned start of empty belt conveyors. Longest delay in the acceleration of the load (Example: 20 seconds)
- Superior choice for high end belt conveyors, low inertia applications, and starting of empty belts
- Incorporates extended (enlarged) delay fill chamber
- At start, the working circuit has least fill. Fluid from the extended delay chamber is metered into the working circuit during acceleration.

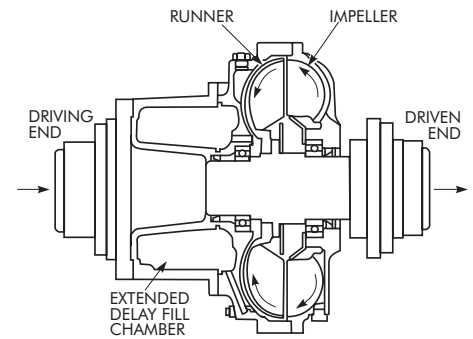

## Choosing the right basic type:

Information above, along with the Quick Selection Tables, enable you to choose the most appropriate basic type of fluid coupling. Where required, Falk can provide engineered fluid coupling selections based on the demand HP and WR<sup>2</sup> of your mechanical system.



## Fluid does the work

At start-up centrifugal force and impeller vane action pump the working fluid against the runner, building torque and speed to match the motor capabilities with the driven machine requirements.

## Standard Features

- 1-1500 HP capacity
- No contacting surfaces to wear out
- Efficiencies to 99%
- Bolted (not welded) construction for simple rebuilds
- High temperature Viton seals for long life
- Internal baffles for soft starts and stalls
- 2 fusible overload plugs  
140°C/200°C for maximum protection
- Fill angle finder makes setup easy
- Externally changeable metering orifices (1420 & larger)
- Standard delay chambers (370 & larger)
- Extended delay chambers (370 & larger)

# Principles of Operation

## Introduction

The working circuit is defined by the Casing, Impeller, and Runner. A conical baffle is attached to the Impeller, and a flat baffle is attached to the Runner. The Impeller and Runner each represent half of a hollow torus, each with flat radial vanes. Torque transfer takes place as follow.

**Driving End (Input)** mechanically transfers torque to the **Casing**.

**Casing** mechanically transfers torque to the **Impeller**.

**Impeller** transfers torque, via the Fluid, to the **Runner**.

**Runner** mechanically transfers torque to the **Shaft**.

**Shaft** mechanically transfers torque to the **Driven End (Output)**.

The Runner has no mechanical connection to the Impeller, these two components are connected by the energized Fluid. If you rotate the Driving End (Input) by hand, the Driven End (Output) does not rotate.

Fluid couplings are furnished without fluid. Customer supplied fluid is added during installation.

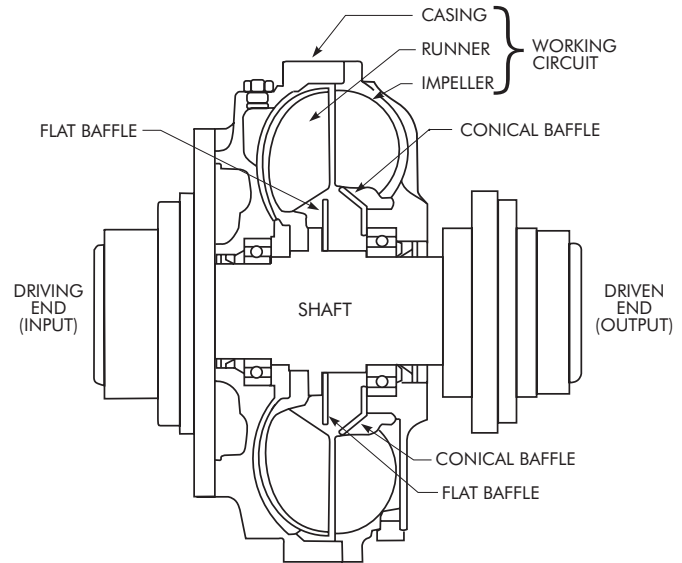

## Starting

Standard NEMA B motors are recommended when using fluid couplings and will start virtually unloaded. Since the motor is mechanically connected to the impeller and casing, the low inertia of these components and the fluid are the only loads imposed. As the electric motor accelerates to running speed, the impeller begins to centrifugally pump fluid to the stationary runner. Initial dispersion of fluid is de-concentrated by the conical impeller baffle, producing a gradual increase in torque, allowing the motor to accelerate rapidly to full running speed. When all the fluid is pumped into the working circuit, continuous circulation of fluid will occur between the impeller and runner. A flow path is formed, shaped like a helical coil that is joined into a closed ring.

As soon as the transmitted torque reaches the value of the load breakaway torque, the runner starts rotating and accelerates the driven load. The time required to reach full speed is dependent on the inertia of the driven load, the resistive torque, and the torque being transmitted by the fluid coupling.

## Running

The operation of a fluid coupling is based on hydrokinetic principles and requires that the output speed be less than the input. This difference in speed is called slip. Further, this principle provides that the output torque is equivalent to the input torque. Therefore, efficiency equals 100% minus the percent of slip.

At full running speed fluid couplings will normally slip between 1% and 4%. The fluid circulation between the impeller and runner has formed a helical coil at the outside circumference of the working circuit and is no longer de-concentrated by the conical baffle.

AT REST

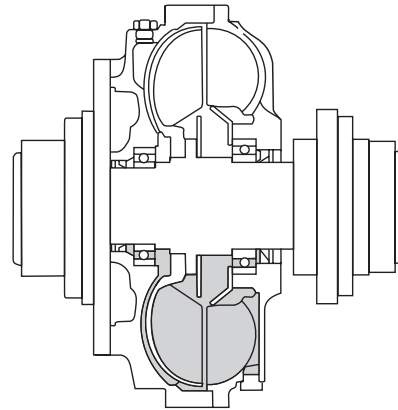

STARTING

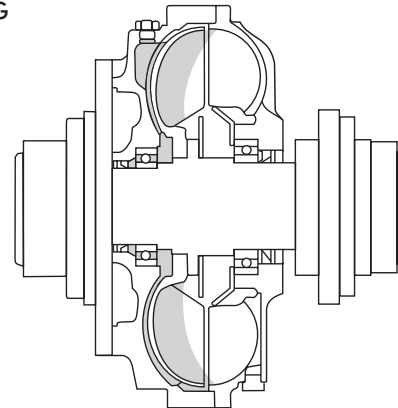

RUNNING

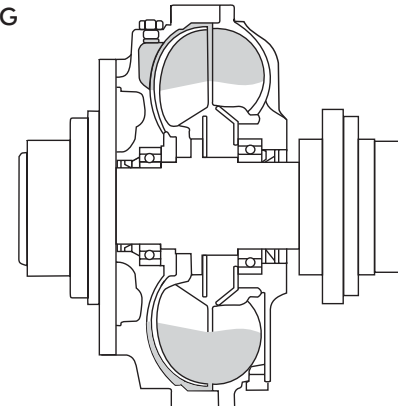

## Overload – stall

Should the load torque increase, the slip will increase, which causes the runner to drop in speed. The coil of fluid circulating between the impeller and runner will expand to provide additional torque. The extent to which this coil can expand is limited by the flat baffle on the runner. Consequently fluid couplings provide inherent overload protection.

If the increase in torque causes the fluid in the working circuit to expand to the point of contacting the baffle, the coupling will stall and slip will be 100%. This continuous high slip generates heat and the fluid temperature will rise unless the overload is removed. When the temperature rises to the temperature limit of the fusible plug, the core of the plug will melt, releasing fluid from the coupling and effectively disconnecting power to the output shaft. To prevent the discharge of fluid, the use of a proximity cutout switch or thermal trip plug and limit switch is recommended, see Page 12.

Coupling guards must be designed to permit the free flow of air for cooling the fluid coupling, and to contain fluid discharge from fusible plug(s) in the event of a sustained overload. Consider Falk Orange Peel coupling guards, which are ideally suited for this purpose.

Falk offers delay fill (HFD) and extended delay fill (HFDD). These solutions provide longer, softer starts, while providing higher efficiencies at full operating speeds.

## Belt conveyors – superior soft start Delay fill (HFD) and extended delay fill (HFDD)

The starting torque that can be transmitted by a fluid coupling is a function of the amount of fluid in the working circuit at start. The delay fill chamber with metering orifice option, bolted to the driving end of Sizes 1420HF thru 2870HF fluid couplings, permits a portion of the fluid to drain out of the working circuit, and into the delay chamber, when the coupling is at rest. This reduction of fluid in the working circuit at startup provides an ideal method to assure superior soft start for belt conveyors, and is effective for starting belts that are loaded or unloaded.

Upon starting, and once the electric motor has accelerated the fluid coupling to appreciable speed, the fluid in the delay chamber is slowly metered into the working circuit by virtue of the (3) metering orifice plugs shown below, gradually increasing the transmitted torque. The time required to completely empty the delay chamber can range from 15 to 60 seconds.

### NORMAL RUNNING CONDITION

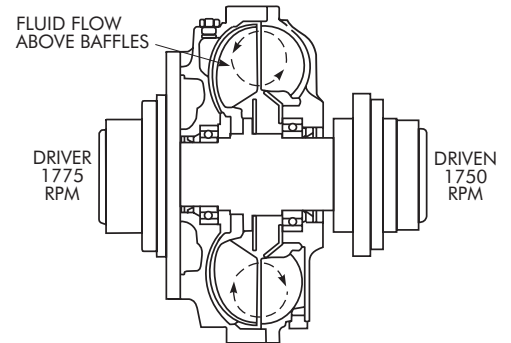

### INCEPTION OF OVERLOAD/STALL

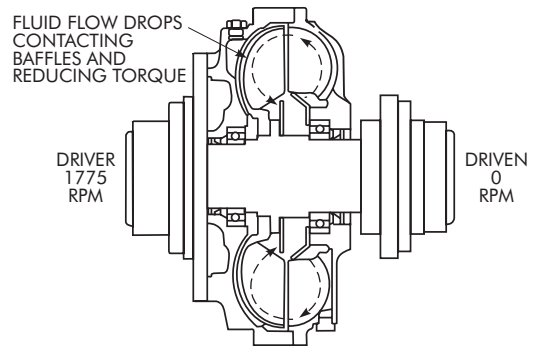

### TYPE HFD DELAY FILL

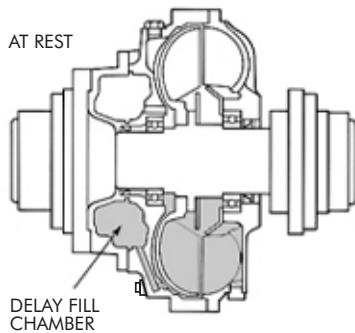

### TYPE HFDD EXTENDED DELAY FILL

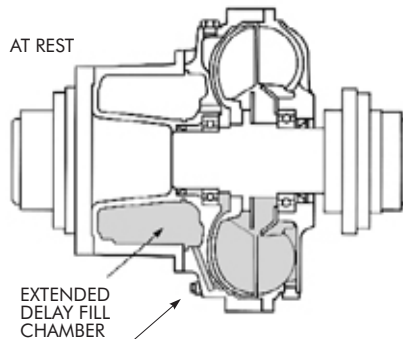

### TYPE HFDD EXTENDED DELAY FILL

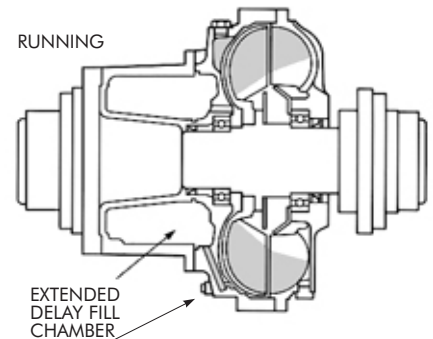

#### SIZES 1420 & LARGER TYPES HFD & HFDD

METERING ORIFICES DETERMINE FLOW RATE FROM FILL CHAMBER TO WORKING CIRCUIT

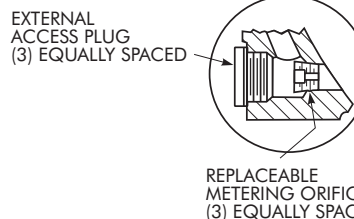

# Accessories For Overload Protection and Prevention of Fluid Discharge

## Proximity Sensor Cutout Switch

The actual speed of the driven shaft is continuously compared to the pre-set cutout speed. The switch includes an adjustable speed control box for manual setting of the cutout speed, usually 80% of normal operating speed. During overload, the instant the driven shaft speed drops below the cutout speed, the cutout switch opens the motor starter circuit, disconnecting the motor electrical supply.

To start the system after the overload is removed, press the start button and hold it until the driven shaft speed exceeds the cutout speed. If the overload has NOT been removed, the starter circuit will again open and shut down the motor when the start button is released because the driven shaft did not exceed the cutout speed. Nothing needs to be replaced or repaired.

For Type HF20, the sensor target can be placed on the output half of the Falk gear coupling. For Types HF31, 31-1, 32 and 32-1, the sensor target would be attached to a shaft on the output side of the fluid coupling. For the HF41, the sensor target would be attached to the end of the fluid coupling opposite the sheave.

For a full description of the proximity sensor cutout switch, see Falk Service Manual 428-440.

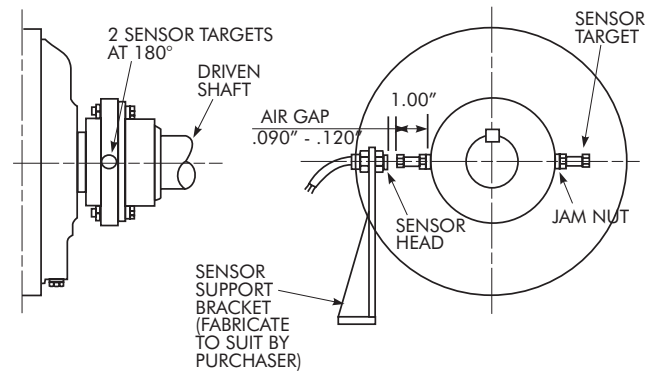

## Thermal Trip Plug & Thermal Trip Switch

Fluid discharge can be prevented by using an optional thermal trip plug in place of the standard fusible plug. When the fluid temperature exceeds a predetermined value, a pin extends to trip a limit switch and cut out the motor. Thermal trip plugs are available in temperatures of 140°C and 180°C. The drive can be reactivated by resetting the motor cut-out and replacing the trip plug. **Note:** For the Type HF41 sheave coupling design (or any reverse mounted fluid coupling), the thermal trip plug/limit switch prevents fluid discharge due to overheating caused by excessive slippage, where the coupling slows down, but does not stall. In this case the trip plug will still rotate and trip the switch in the event of overheating. If the requirement is to trip a switch in the event of a total jam in the system (outer case of fluid coupling at zero rpm & plug cannot rotate through switch), use proximity sensor cutout switch above. For a full description of the thermal trip plug and thermal trip switch, see Falk service manual 528-510.

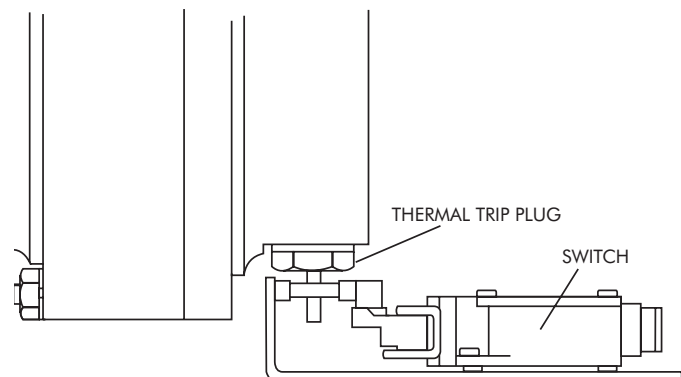

## Orange Peel® Coupling Guards

Falk Orange Peel Coupling Guards offer a convenient, economical enclosure for rotating couplings.

FLUID COUPLING SIZE	Orange Peel Guard Selection ‡
185HF	CFCG30
235HF	CFCG40
270HF	CFCG40
320HF	CFCG50
370HF	CFCG50
1420HF - 1660HF > 1660HF	See Orange Peel Selection Guide 111-310 Refer to Falk

‡ Review site conditions versus guard dimensions to assure proper clearances for guard are present.

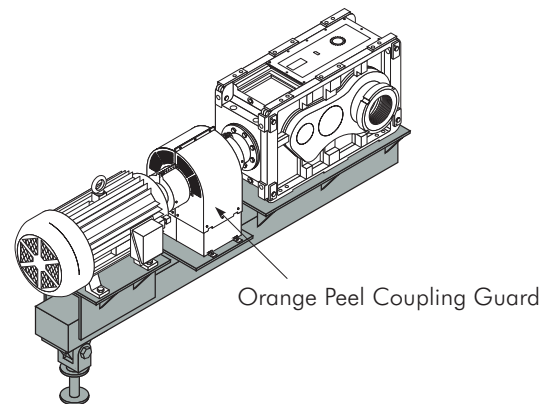

# Other Accessories

## Falk angle finder (Part No. 1224653)

Each fluid coupling is shipped with an angle finder. Reorder in case of loss or damage. The Falk angle finder will ease the task of filling the fluid coupling to the specified fill angle. Setup time is reduced, because the Falk angle finder is direct-reading. Simply place the angle finder on the filler plug boss and rotate the coupling to the required fill angle.

## Provide soft start plus holdback – or – Control the overrun tendencies of specific applications

### Falk fluid coupling/disc brake package

Falk fluid coupling/disc brake packages are versatile designs that can be customized to meet your specific needs. The superior performance inherent in disc brakes, combined with the benefits of a fluid coupling, provide an ideal package for inclined conveyors where soft start and holdback are required for the process of moving loads from a lower elevation to a higher elevation. The package consists of a fluid coupling and a Type G63 coupling (Gear coupling with brake disc incorporated). The brake disc is designed to be compatible with hydraulic calipers that are actuated by a Falk supplied hydraulic power pack.

In the illustration below, the G63 mounting of the brake disc is shown. Note that application of the brake takes place at the output side of the fluid coupling. This arrangement assures that braking is applied directly to the driven shaft.

The use of a fluid coupling/brake disc package to retard overrun tendencies associated with specific applications, or to retard eccentric loads that wish to roll back to a neutral centered position, requires significant analysis and should be referred to Falk.



### TYPE G63 – FLUID COUPLING WITH GEAR COUPLING AND BRAKE DISC

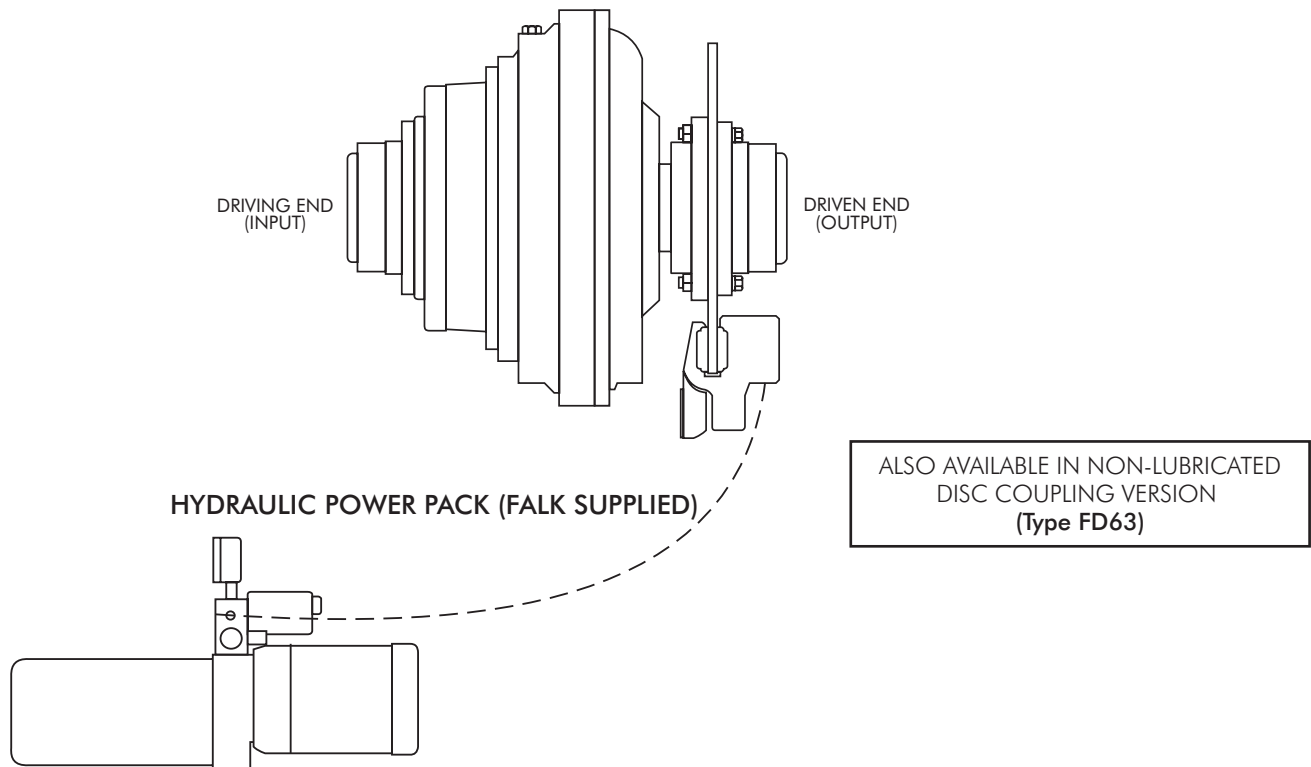

# How to select

The Falk fluid coupling is a multiple use device:

- Provide soft cushioned starts
- Provide increased starting torque
- Provide overload protection
- Reduce current draw when starting
- Provide load balancing for multiple drives
- Provide load dampening

To achieve these objectives, use a standard NEMA B motor with sufficient breakdown torque to start the machinery and with adequate continuous rating for the normal continuous load. The function of the fluid coupling is to allow the motor to come up to speed with minimum load.

The fluid coupling is selected on the basis of the full load running horsepower as well as the torque required to start the load. In some applications, such as belt conveyors, it may be desirable to limit the maximum starting torque. If possible, select the coupling on the basis of the load rather than the motor rating, especially if the motor is oversized. Couplings that are selected on the basis of the motor size will have starting torque and maximum overload torques in relation to the motor rating.

## Selection procedure

1. Determine the running load horsepower (preferred) or the motor horsepower.
2. **Choose a Start Factor from the Table below.** Start Factor: the ratio of a pertinent starting torque to the running load torque (the torque required to maintain the load (speed) once equipment has been accelerated to its design speed)

**For Belt Conveyors (Select from Pages 16 & 17).** Start Factor is the average starting torque exerted by the fluid coupling during load acceleration, expressed as a percent of running load torque. Page 17 (HFDD) also states initial start factor, which is the nominal torque applied at the inception of acceleration, expressed as a percent of running load torque. The low initial start factor (HFDD) assures an extra soft empty belt start on low inertia conveyors, yet is adequate to overcome the breakaway torque of the conveyor.

**General Duty (Other than Belt Conveyors),** select from Pages 18 thru 21, Start Factor is equivalent to the initial start factor mentioned in the paragraph above. For these General Duty applications, the initial start factor insures breakaway of the driven machinery.

## Start Factor Table

Applications	Start Factor	Select From
<b>Belt Conveyors</b>	120% to 140%	Pages 16-17
<b>General Duty</b>		
<b>Fans</b>	140%	Pages 18-21
<b>Mixers</b>	170% to 200%	Pages 18-21
<b>Crushers</b>	250%	Pages 18-21
<b>Armored Face Conveyors</b>	Refer to Falk	Refer to Falk

3. Refer to the Quick Selection Tables (Pages 16 thru 21).

For Belt Conveyors, select HFN or HFD from Page 16. For extra soft empty belt starts on low inertia belt conveyors, consider HFDD selections on Page 17.

For General Duty (Other than Belt Conveyors), select HFD or HFN/HFR from Pages 18 thru 21.

Note the percent slip and fill angle.

4. Select a Mounting Arrangement (gear coupling, disc coupling, etc.) from Page 8.
5. For coupling size, basic type, and mounting arrangement selected, see **Availability Table**, Page 15. Table indicates whether the selection is available, and if so, the allowable speed.
6. If initial basic type and mounting arrangement not available, or insufficient allowable speed, consider alternative basic type/mounting arrangement.
7. Check bore capacity of the coupling selected, dimension tables, Pages 22 thru 31.

## Selection example:

1. Belt Conveyor: Fluid coupling connects a motor to the input shaft of a gear drive. Motor is NEMA B, rated 100 HP at 1775 rpm. Running load = 98 HP. Motor shaft 2.875", gear drive input shaft 2.250".
2. Start Factor 1.20 to 1.40, select from Pages 16 & 17 as appropriate (selections for Belt Conveyors).
3. **HFD** selections for Belt Conveyors, Page 16. For 98 HP running load, select 370HFD, 4.1% slip, fill angle 63 degrees.
4. Select 370HFD20 (Gear Coupling mount) from Page 8, economical, and includes drop-in/drop-out servicing.
5. Availability Table Page 15, 370HFD20 is available, allowable speed is 1800 rpm, exceeds the requirement of 1775 rpm.
6. Alternative basic type/mounting arrangements are listed on Page 15.
7. Page 23, dimensions, max bore is 2.875", which is adequate.

# Fluid Coupling Identification

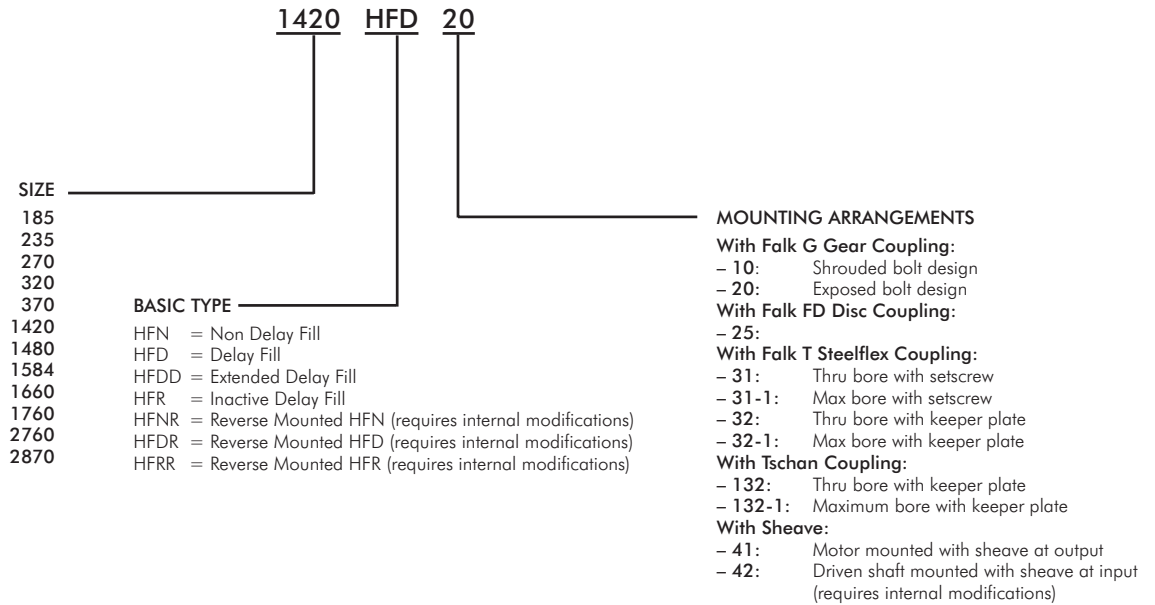

## Availability Table (by Basic Type & Mounting Arrangement)

(An Allowable Speed indicates that the fluid coupling Basic Type and Mounting Arrangement is available for the given size)

Basic Type		Mounting Arrangement	Coupling Size & Allowable Speed (rpm)												
			185	235	270	320	370	1420	1480	1584	1660	1760	2760	2870	
Gear	HFN	10	1800	1800	1800	1800	1800	1800	1800	1800					
	HFN	20	1800	1800	1800	1800	1800	1800	1800	1800					
	HFD	20	...	...	...	...	...	1800	1800	1800	1500	1200			
	HFDD	20	...	...	...	...	...	...	1800	1800	1500	1200			
Gear	HFR	20	...	...	...	...	...	...	1800	1500	1200				
Steelflex	HFN	31	...	...	...	1800	...	...	...	...	...	...	...	...	...
	HFD	31, 31-1	...	...	...	...	1800	1800	1800	...	...	...	...	...	...
	HFR	31, 31-1	...	...	...	...	1800	1800	1800	...	...	...	...	...	...
	HFN	32, 32-1	...	...	...	1800	...	...	...	...	...	...	...	...	...
	HFD	32, 32-1	...	...	...	...	1800	1800	1800	1800	1800	1500	1800	...	...
	HFR	32, 32-1	...	...	...	...	1800	1800	1800	1800	1800	1500	1800	...	...
Disc	HFN	25	...	...	...	...	...	...	...	...	...	...	...	...	1500
	HFD	25	...	...	...	...	1800	1800	1800	1800	1800	1500	1800	1500	1500
	HFDD	25	...	...	...	...	...	1800	1800	1800	1800	1500	1800	1800	1500
	HFR	25	...	...	...	...	...	1800	1800	1800	1800	1500	1800	1800	1500
Tschan	HFD	132, 132-1	...	...	...	...	1800	1800	1800	1800	1800	1500	1800	...	...
	HFDD	132, 132-1	...	...	...	...	...	1800	1800	1800	1800	1500	1800	...	...
	HFR	132, 132-1	...	...	...	...	1800	1800	1800	1800	1800	1500	1800	...	...
Sheave	HFN	41	1800	1800	1800	1800	1800	1800	1800	1800	1800				
	HFD	41	...	...	...	...	1800	1800	1800	1800	1800				

# HFN & HFD for Belt Conveyors ★

## Quick Selection Table 1775-870 rpm input speed

Load Horse-power	START FACTOR 140% FOR BELT CONVEYORS †															Load Horse-power
	1775RPM			1450RPM			1170 RPM			970 RPM			870 RPM			
	HFN & HFD			HFN & HFD			HFN & HFD			HFN & HFD			HFN & HFD			
	COUPLING SIZE	% SLIP	FILL ANGLE	COUPLING SIZE	% SLIP	FILL ANGLE	COUPLING SIZE	% SLIP	FILL ANGLE	COUPLING SIZE	% SLIP	FILL ANGLE	COUPLING SIZE	% SLIP	FILL ANGLE	
<b>1.00</b>	185	5.0	85	185	4.4	75	185	6.6	61	235	4.2	75	235	4.9	70	<b>1.00</b>
<b>1.25</b>	185	4.9	81	185	4.5	71	235	4.9	80	235	4.7	71	235	7.5	65	<b>1.25</b>
<b>1.50</b>	185	5.0	78	185	5.1	67	235	4.8	77	235	5.1	68	270	3.0	70	<b>1.50</b>
<b>1.75</b>	185	5.0	76	185	6.0	63	235	4.4	75	235	6.1	63	270	3.9	67	<b>1.75</b>
<b>2.00</b>	185	4.7	74	185	7.1	60	235	5.0	73	235	6.6	60	270	4.2	65	<b>2.00</b>
<b>2.50</b>	185	4.7	70	235	4.9	79	235	4.8	68	270	3.8	68	270	6.3	60	<b>2.50</b>
<b>3.00</b>	185	5.4	65	235	4.5	76	235	6.1	64	270	4.5	64	320	3.3	74	<b>3.00</b>
<b>4.00</b>	235	4.7	81	235	5.0	72	270	3.3	69	320	3.2	75	320	3.6	68	<b>4.00</b>
<b>5.00</b>	235	5.1	78	235	5.2	67	270	4.4	65	320	3.2	71	320	4.7	64	<b>5.00</b>
<b>6.25</b>	235	4.6	75	235	6.5	61	270	6.8	60	320	4.0	66	370	2.7	83	<b>6.25</b>
<b>7.50</b>	235	4.4	71	270	3.3	69	320	3.3	73	320	5.1	63	370	2.8	77	<b>7.50</b>
<b>8.75</b>	235	4.8	68	270	4.0	66	320	3.1	70	370	2.7	83	370	3.0	72	<b>8.75</b>
<b>10.0</b>	235	5.6	65	270	4.8	64	320	3.7	67	370	2.8	79	370	3.4	68	<b>10.0</b>
<b>12.5</b>	270	3.2	71	270	7.4	59	320	4.9	63	370	3.0	72	370	4.4	61	<b>12.5</b>
<b>15.0</b>	270	3.9	68	320	3.2	72	370	2.7	83	370	3.6	66	1420	3.0	75	<b>15.0</b>
<b>17.5</b>	270	4.4	65	320	3.3	69	370	2.8	78	1420	2.6	81	1420	3.1	70	<b>17.5</b>
<b>20.0</b>	270	5.7	62	320	3.8	66	370	3.0	74	1420	2.8	77	1420	3.7	66	<b>20.0</b>
<b>22.5</b>	270	7.0	59	320	4.4	64	370	3.1	70	1420	3.0	73	1420	4.1	62	<b>22.5</b>
<b>25.0</b>	320	3.5	75	320	5.4	62	370	3.5	67	1420	3.1	70	1420	4.6	59	<b>25.0</b>
<b>27.5</b>	320	3.2	72	370	2.7	84	370	3.9	64	1420	3.5	67	1480	2.8	77	<b>27.5</b>
<b>30.0</b>	320	3.0	70	370	2.6	81	1420	2.6	81	1420	3.8	64	1480	3.0	74	<b>30.0</b>
<b>35.0</b>	320	3.7	67	370	2.9	77	1420	2.8	76	1480	2.7	80	1480	3.2	69	<b>35.0</b>
<b>40.0</b>	320	4.2	65	370	3.0	72	1420	3.0	72	1480	2.8	76	1480	3.7	65	<b>40.0</b>
<b>45.0</b>	320	5.1	62	370	3.3	69	1420	3.3	68	1480	3.1	73	1480	4.3	62	<b>45.0</b>
<b>50.0</b>	370	2.7	84	370	3.6	65	1420	3.7	65	1480	3.2	69	1584	2.6	88	<b>50.0</b>
<b>55.0</b>	370	2.6	81	1420	2.6	82	1480	2.7	83	1480	3.6	66	1584	2.7	85	<b>55.0</b>
<b>60.0</b>	370	2.8	79	1420	2.7	79	1480	2.7	80	1584	2.7	92	1584	2.7	83	<b>60.0</b>
<b>67.5</b>	370	3.0	75	1420	2.9	76	1480	2.9	77	1584	2.5	89	1584	2.7	79	<b>67.5</b>
<b>75.0</b>	370	3.1	72	1420	3.0	72	1480	3.0	73	1584	2.6	86	1584	2.8	76	<b>75.0</b>
<b>87.5</b>	370	3.6	67	1420	3.5	68	1480	3.3	68	1584	2.6	82	1584	3.0	71	<b>87.5</b>
<b>100.0</b>	370	4.1	63	1480	2.7	84	1480	3.8	64	1584	2.8	78	1584	3.5	67	<b>100.0</b>
<b>112.5</b>	1420	2.8	79	1480	2.7	81	1584	2.4	89	1584	3.0	75	1584	4.6	61	<b>112.5</b>
<b>125.0</b>	1420	2.9	76	1480	2.8	77	1584	2.6	87	1584	3.0	71	1660	2.7	79	<b>125.0</b>
<b>137.5</b>	1420	3.0	72	1480	2.9	74	1584	2.8	85	1584	3.3	68	1660	2.8	76	<b>137.5</b>
<b>150.0</b>	1420	3.2	70	1480	3.1	72	1584	2.6	82	1584	3.7	66	1660	3.1	73	<b>150.0</b>
<b>175.0</b>	1420	3.7	65	1480	3.5	67	1584	2.8	77	1660	2.8	80	1660	3.3	69	<b>175.0</b>
<b>200.0</b>	1480	2.7	82	1584	2.6	91	1584	3.0	73	1660	2.9	76	1660	3.8	65	<b>200.0</b>
<b>225.0</b>	1480	2.8	78	1584	2.5	88	1584	3.2	69	1660	3.0	72	1660	4.2	61	<b>225.0</b>
<b>250.0</b>	1480	3.0	75	1584	2.7	86	1584	3.6	66	1660	3.3	69	1760	2.8	80	<b>250.0</b>
<b>275.0</b>	1480	3.1	72	1584	2.7	83	1660	2.6	82	1760	2.6	87	1760	2.9	77	<b>275.0</b>
<b>300.0</b>	1480	3.3	69	1584	2.7	81	1660	2.8	80	1760	2.8	85	1760	3.0	74	<b>300.0</b>
<b>325.0</b>	1584	2.6	93	1584	2.8	78	1660	2.8	77	1760	2.6	82	1760	3.0	71	<b>325.0</b>
<b>350.0</b>	1584	2.6	92	1584	2.9	76	1660	3.0	75	1760	2.7	80	1760	3.2	69	<b>350.0</b>
<b>375.0</b>	1584	2.7	91	1584	3.0	74	1660	3.1	73	1760	2.8	78	1760	3.5	67	<b>375.0</b>
<b>400.0</b>	1584	2.5	89	1584	3.1	72	1660	3.1	71	1760	2.8	76	1760	3.7	65	<b>400.0</b>
<b>425.0</b>	1584	2.6	88	1584	3.2	70	1660	3.3	69	1760	3.0	74	1760	4.0	63	<b>425.0</b>
<b>450.0</b>	1584	2.6	86	1660	2.6	86	1660	3.5	67	1760	3.0	72	2870	3.8	67	<b>450.0</b>
<b>475.0</b>	1584	2.8	85	1660	2.8	85	1660	3.6	65	1760	3.1	71	2870	3.8	66	<b>475.0</b>
<b>500.0</b>	1584	2.6	83	1660	2.8	84	1760	2.7	85	1760	3.2	69	2870	3.8	65	<b>500.0</b>
<b>550.0</b>	1584	2.7	81	1660	2.7	81	1760	2.7	83	*	*	*	2870	3.9	62	<b>550.0</b>
<b>600.0</b>	1584	2.8	78	1660	2.8	78	1760	2.7	80	*	*	*	2870	4.0	61	<b>600.0</b>
<b>650.0</b>	1660	2.7	92	1760	2.7	94	1760	2.8	78	*	*	*	2870	4.3	60	<b>650.0</b>
<b>700.0</b>	1660	2.4	90	1760	2.6	92	1760	2.9	75	*	*	*	*	*	*	<b>700.0</b>
<b>750.0</b>	1660	2.6	89	1760	2.6	91	1760	3.0	73	*	*	*	*	*	*	<b>750.0</b>
<b>800.0</b>	1660	2.5	86	1760	2.4	89	2870	3.8	74	*	*	*	*	*	*	<b>800.0</b>
<b>850.0</b>	2760	2.3	99	1760	2.6	88	2870	3.8	73	*	*	*	*	*	*	<b>850.0</b>
<b>900.0</b>	2760	2.4	98	1760	2.7	87	2870	3.8	72	*	*	*	*	*	*	<b>900.0</b>
<b>950.0</b>	2760	2.4	97	1760	2.7	85	*	*	*	*	*	*	*	*	*	<b>950.0</b>
<b>1000.0</b>	2760	2.6	97	2870	4.0	84	*	*	*	*	*	*	*	*	*	<b>1000.0</b>
<b>1100.0</b>	2760 ‡	2.3	94	2870	3.6	81	*	*	*	*	*	*	*	*	*	<b>1100.0</b>
<b>1200.0</b>	2760 ‡	2.3	92													<b>1200.0</b>
<b>1250.0</b>	2760 ‡	2.2	91													<b>1250.0</b>

★ Selections above the **BOLD** line are HFN. Selections below the **BOLD** line are HFD.

■ For 1584HFD and 1660HFD in the shaded area, see Page 15 for Availability Table (by Basic Type and Mounting Arrangement). Choose a mounting arrangement with adequate allowable speed for the application.

† Start Factor 140% for belt conveyors is the average starting torque exerted by the fluid coupling during load acceleration, expressed as a percent of running load torque.

‡ Based on 150% Start Factor.

\* Refer to Falk.



# HFDD for Belt Conveyors

## Quick Selection Table 1775-1170 rpm input speed

Load Horse-power	START FACTOR 120% FOR BELT CONVEYORS †												Load Horse-power
	1775 RPM				1450 RPM				1170 RPM				
	COUPLING SIZE	% SLIP	FILL ANGLE	INITIAL START FACTOR •	COUPLING SIZE	% SLIP	FILL ANGLE	INITIAL START FACTOR •	COUPLING SIZE	% SLIP	FILL ANGLE	INITIAL START FACTOR •	
35.0	...	...	...	...	...	...	...	...	1420	3.2	91	0.60	35.0
40.0	...	...	...	...	...	...	...	...	1420	3.5	89	0.55	40.0
45.0	...	...	...	...	...	...	...	...	1420	3.8	86	0.54	45.0
50.0	...	...	...	...	...	...	...	...	1420	4.1	84	0.54	50.0
55.0	...	...	...	...	...	...	...	...	1420	4.8	82	0.53	55.0
60.0	...	...	...	...	...	...	...	...	1420	5.0	80	0.52	60.0
67.5	...	...	...	...	1420	3.1	91	0.55	1480	3.2	92	0.58	67.5
75.0	...	...	...	...	1420	3.3	90	0.52	1480	3.4	89	0.56	75.0
87.5	...	...	...	...	1420	3.7	86	0.53	1480	3.8	85	0.59	87.5
100.0	...	...	...	...	1420	4.1	83	0.53	1480	4.3	82	0.60	100.0
112.5	...	...	...	...	1420	4.9	81	0.52	1480	5.0	78	0.60	112.5
125.0	1420	3.3	90	0.58	1480	3.3	94	0.48	1584	3.3	98	0.49	125.0
137.5	1420	3.5	88	0.58	1480	3.2	91	0.52	1584	3.3	96	0.48	137.5
150.0	1420	3.7	86	0.58	1480	3.3	88	0.55	1584	3.3	94	0.48	150.0
175.0	1420	4.3	83	0.57	1480	3.8	85	0.54	1584	3.3	91	0.58	175.0
200.0	1420	4.5	78	0.58	1480	4.3	81	0.74	1584	3.4	88	0.58	200.0
225.0	1480	3.2	92	0.56	1584	3.6	99	0.45	1584	3.7	83	0.66	225.0
250.0	1480	3.3	89	0.59	1584	3.4	98	0.45	1584	4.0	80	0.66	250.0
275.0	1480	3.5	87	0.59	1584	3.3	96	0.48	1584	4.5	77	0.66	275.0
300.0	1480	3.5	81	0.90	1584	3.3	95	0.48	1584	4.5	72	0.72	300.0
325.0	1584	3.3	102	0.46	1584	3.3	93	0.50	1660	3.3	90	0.62	325.0
350.0	1584	3.6	101	0.48	1584	3.1	90	0.56	1660	3.3	88	0.61	350.0
375.0	1584	3.6	100	0.50	1584	3.3	88	0.60	1660	3.4	86	0.60	375.0
400.0	1584	3.7	99	0.52	1584	3.3	86	0.62	1660	3.5	84	0.61	400.0
425.0	1584	3.5	98	0.53	1584	3.5	85	0.62	1660	3.7	82	0.67	425.0
450.0	1584	3.2	97	0.54	1584	3.4	80	0.68	1660	3.7	79	0.70	450.0
475.0	1584	3.2	96	0.55	1660	3.1	97	0.47	1760	3.4	99	0.43	475.0
500.0	1584	3.3	95	0.56	1660	3.2	96	0.49	1760	3.3	97	0.53	500.0
550.0	1660	3.1	103	0.50	1660	3.3	94	0.48	1760	3.2	95	0.56	550.0
600.0	1660	3.3	102	0.53	1660	3.0	89	0.66	1760	3.2	93	0.58	600.0
650.0	1660	2.9	100	0.53	1760	3.3	104	0.40	1760	3.2	92	0.57	650.0
700.0	1660	2.6	97	0.54	1760	3.3	103	0.40	1760	3.2	91	0.56	700.0
750.0	1660	2.6	95	0.55	1760	3.1	101	0.46	1760	3.2	90	0.55	750.0
800.0	1660	2.1	91	*	1760	3.0	100	0.50	2870	2.9	87	*	800.0
850.0	1660	2.2	90	*	1760	3.0	98	0.54	2870	3.0	86	*	850.0
900.0	1660	2.1	89	*	1760	3.0	97	0.55	2870	3.0	85	*	900.0
950.0	2760	2.0	102	*	2870	2.7	93	*	2870	3.1	84	*	950.0
1000.0	2760	1.4	100	*	2870	2.7	92	*	2870	3.2	83	*	1000.0
1100.0	2760	1.6	98	*	2870	2.7	91	*	2870	3.3	82	*	1100.0
1200.0	2760	1.5	96	*	2870	2.7	90	*					1200.0
1250.0	2760	1.4	95	*	2870	2.7	89	*					1250.0
1300.0					2870	2.7	89	*					1300.0
1400.0					2870	2.7	88	*					1400.0
1500.0					2870	2.7	86	*					1500.0

■ For 1584HFDD and 1660HFDD selections in the shaded area, see Page 15 for Availability Table (by Basic Type and Mounting Arrangement). Choose a mounting arrangement with adequate allowable speed for the application.

† Start Factor 120% for belt conveyors is the average starting torque exerted by the fluid coupling during load acceleration, expressed as a percent of running load torque.

• Initial start factor for HFDD selections is the nominal torque applied at the inception of acceleration, expressed as a percent of running load torque. The low initial start factor assures an extra soft empty belt start on low inertia conveyors, yet is adequate to overcome the breakaway torque of the conveyor.

\* Refer to Falk.

# General Duty (Other than Belt Conveyors) Quick Selection Table 1775 rpm input speed

Load Horse-power	GENERAL DUTY START FACTOR †																		Load Horse-power						
	140%						170%						200%							250%					
	HFD			HFN/HFR*			HFD			HFN/HFR*			HFD			HFN/HFR*				HFD			HFN/HFR*		
	COUPLING SIZE	% SLIP	FILL ANGLE	COUPLING SIZE	% SLIP	FILL ANGLE	COUPLING SIZE	% SLIP	FILL ANGLE	COUPLING SIZE	% SLIP	FILL ANGLE	COUPLING SIZE	% SLIP	FILL ANGLE	COUPLING SIZE	% SLIP	FILL ANGLE		COUPLING SIZE	% SLIP	FILL ANGLE	COUPLING SIZE	% SLIP	FILL ANGLE
1.00				185	6.7	88				185	4.6	84				185	3.1	80				185	1.8	76	1.00
1.25				185	5.9	82				185	4.0	79				185	2.6	76				185	1.8	73	1.25
1.50				185	6.2	80				185	3.7	76				185	2.4	73				185	1.7	69	1.50
1.75				185	5.3	76				185	3.3	73				185	2.6	71				185	1.9	66	1.75
2.00				185	5.2	75				185	3.4	71				185	2.7	68				185	2.1	63	2.00
2.50				185	5.5	71				185	4.0	67				185	3.2	63				185	2.4	53	2.50
3.00				185	6.4	67				185	4.6	62				185	3.7	55				235	2.0	78	3.00
4.00				235	5.6	81				235	4.2	80				235	2.9	77				235	1.7	73	4.00
5.00				235	5.8	79				235	3.7	76				235	2.5	73				235	1.7	69	5.00
6.25				235	4.7	75				235	3.5	72				235	2.6	69				235	1.9	64	6.25
7.50				235	5.2	72				235	3.6	69				235	2.8	65				235	2.2	58	7.50
8.75				235	5.1	69				235	4.3	66				235	3.2	61				270	1.8	66	8.75
10.0				235	6.6	67				235	4.7	62				235	3.7	55				270	2.0	64	10.0
12.5				270	3.2	71				235	5.6	50				270	2.6	64				270	2.1	59	12.5
15.0				270	3.7	67				270	3.2	63				270	2.9	60				270	2.3	53	15.0
17.5				270	4.3	64				270	3.9	60				270	3.3	56				320	1.6	69	17.5
20.0				270	5.7	62				270	4.6	57				320	2.1	71				320	1.7	67	20.0
22.5				270	7.0	59				270	4.8	52				320	2.1	69				320	2.0	65	22.5
25.0				320	3.5	75	370	1.7	94	320	2.5	70	370	1.1	87	320	2.3	67	370	0.8	79	320	2.1	63	25.0
27.5	370	2.9	98	320	3.2	72	370	1.3	89	320	2.6	68	370	1.2	83	320	2.5	65	370	0.9	76	320	2.2	61	27.5
30.0	370	2.3	94	320	3.0	70	370	1.4	86	320	2.8	66	370	1.0	80	320	2.6	63	370	0.9	74	320	2.2	59	30.0
35.0	370	1.8	87	320	3.7	67	370	1.3	80	320	3.3	64	370	1.1	75	320	2.9	60	370	0.9	70	320	2.3	53	35.0
40.0	370	1.9	82	320	4.2	65	370	1.5	76	320	3.8	61	370	1.2	72	320	3.3	57	370	1.0	67	370	1.7	67	40.0
45.0	370	1.8	78	320	5.1	62	370	1.5	73	320	4.4	58	370	1.2	70	320	3.4	52	370	1.2	65	370	1.9	65	45.0
50.0	370	1.9	75	370	3.3	75	370	1.6	70	320	4.8	55	370	1.4	67	370	2.2	67	370	1.3	63	370	2.0	63	50.0
55.0	370	2.0	73	370	3.4	73	370	1.7	69	370	2.6	69	370	1.6	66	370	2.4	66	370	1.5	61	370	2.1	61	55.0
60.0	370	2.1	71	370	3.2	71	370	1.9	67	370	2.7	67	370	1.8	64	370	2.6	64	370	1.7	60	370	2.2	60	60.0
67.5	370	2.3	69	370	3.3	69	370	2.3	65	370	3.1	65	370	2.1	62	370	2.8	62	370	1.8	56	370	2.2	56	67.5
75.0	370	2.7	67	370	4.0	67	370	2.6	63	370	3.4	63	370	2.5	60	370	3.1	60	370	1.8	51	370	2.2	51	75.0
87.5	370	3.3	64	370	4.7	64	370	3.1	60	370	4.2	60	370	2.6	55	370	3.4	55	1420	1.2	65	1420	1.9	65	87.5
100.0	370	3.9	61	1420	3.3	74	370	3.4	56	370	4.7	56	1420	1.6	66	1420	2.3	66	1420	1.4	62	1420	2.1	62	100.0
112.5	1420	2.1	71	1420	3.2	71	1420	1.9	67	1420	2.7	67	1420	1.8	64	1420	2.6	64	1420	1.7	60	1420	2.2	60	112.5
125.0	1420	2.3	69	1420	3.3	69	1420	2.2	65	1420	3.1	65	1420	2.1	62	1420	2.7	62	1420	1.8	57	1420	2.3	57	125.0
137.5	1420	2.6	67	1420	3.8	67	1420	2.4	63	1420	3.3	63	1420	2.3	60	1420	2.9	60	1420	1.8	53	1420	2.3	53	137.5
150.0	1420	2.9	65	1420	4.0	65	1420	2.8	62	1420	3.7	62	1420	2.5	58	1420	3.2	58	1480	1.1	67	1480	1.7	67	150.0
175.0	1420	3.5	62	1420	5.1	62	1420	3.2	58	1420	4.4	58	1420	2.7	52	1420	3.4	52	1480	1.3	64	1480	2.0	64	175.0
200.0	1480	2.0	73	1480	3.3	73	1420	3.6	54	1480	2.5	69	1480	1.6	66	1480	2.4	66	1480	1.5	62	1480	2.1	62	200.0
225.0	1480	2.2	71	1480	3.2	71	1480	1.9	67	1480	2.8	67	1480	1.9	64	1480	2.7	64	1480	1.7	59	1480	2.2	59	225.0
250.0	1480	2.3	68	1480	3.4	68	1480	2.3	65	1480	3.2	65	1480	2.1	62	1480	2.8	62	1480	1.8	56	1480	2.3	56	250.0
275.0	1480	2.7	67				1480	2.5	63	1480	3.4	63	1480	2.4	60	1480	3.1	60	1480	1.8	51	1480	2.2	51	275.0
300.0	1480	3.0	65				1480	2.8	61	1584	5.4	85	1480	2.5	57	1480	3.2	57	1584	0.9	73	1584	1.4	73	300.0
325.0	1584	1.8	90				1480	3.0	59	1584	4.9	82	1480	2.7	55	1584	2.7	77	1584	0.9	71	1584	1.5	71	325.0
350.0	1584	1.9	87				1584	1.4	80	1584	3.7	80	1480	2.6	50	1584	1.8	75	1584	0.9	70	1584	1.6	70	350.0
375.0	1584	2.0	84				1584	1.4	77	1584	3.3	77	1584	1.2	73	1584	1.9	73	1584	1.0	68	1584	1.6	68	375.0
400.0	1584	1.9	82				1584	1.5	76	1584	3.1	76	1584	1.2	72	1584	2.1	72	1584	1.1	67	1584	1.7	67	400.0
425.0	1584	1.8	80				1584	1.5	74	1584	2.4	74	1584	1.2	70	1584	2.0	70	1584	1.2	66	1584	1.8	66	425.0
450.0	1584	1.9	78				1584	1.5	73	1584	2.5	73	1584	1.3	69	1584	2.1	69	1584	1.2	65	1584	1.9	65	450.0
475.0	1584	1.9	76				1584	1.5	71	1584	2.6	71	1584	1.4	68	1584	2.1	68	1584	1.3	64	1584	2.0	64	475.0
500.0	1584	2.0	75				1584	1.5	70	1584	2.4	70	1584	1.5	67	1584	2.2	67	1584	1.4	63	1584	2.1	63	500.0
550.0	1584	2.0	72				1584	1.7	68	1584	2.6	68	1584	1.7	65	1584	2.5	65	1584	1.5	61	1584	2.1	61	550.0
600.0	1584	2.2	71				1584	1.9	67	1584	2.8	67	1584	1.9	64	1584	2.7	64	1584	1.7	59	1584	2.2	59	600.0
650.0	1584	2.3	69				1584	2.2	65	1660	3.1	78 †	1584	2.1	62	1660	1.8	75	1584	1.8	57	1584	2.3	57	650.0
700.0	1660	2.0	84				1584	2.4	64	1660	2.9	76 †	1584	2.3	61	1660	1.9	73	1584	1.8	54	1584	2.3	54	700.0
750.0	1660	1.9	81				1660	1.4	75	1660	2.4	75	1660	1.2	71	1660	2.1	71	1660	1.1	67	1660	1.8	67	750.0
800.0	1660	1.9	79				1660	1.5	73	1660	2.4	73	1660	1.2	70	1660	2.1	70	1660	1.2	66	1660	1.9	66	800.0
850.0	1660	1.9	77				1660	1.5	72				1660	1.3	69	1660	2.2	69	1660	1.2	64	1660	1.9	64	850.0
900.0	1660	1.9	75				1660	1.6	71				1660	1.4	68	1660	2.2	68	1660	1.3	63	1660	2.0	63	900.0
950.0	2760	2.7	99				2760	1.5	92				2760	1.3	85				2760	0.8	78	1660	2.1	62	950.0
1000.0	2760	2.8	98				2760	1.3	90				2760	1.2	83				2760	0.9	76				1000.0
1100.0	2760	2.3	94				2760	1.4	86				2760	1.0	80				2760	0.9	74				1100.0
1200.0	2760	1.8	90				2760	1.5	83				2760	1.2	77				2760	0.9					

# General Duty (Other than Belt Conveyors) Quick Selection Table 1450 rpm input speed

Load Horse-power	GENERAL DUTY START FACTOR †																		Load Horse-power						
	140%						170%						200%							250%					
	HFD			HFN/HFR*			HFD			HFN/HFR*			HFD			HFN/HFR*				HFD			HFN/HFR*		
	COUPLING SIZE	% SUP	FILL ANGLE	COUPLING SIZE	% SUP	FILL ANGLE	COUPLING SIZE	% SUP	FILL ANGLE	COUPLING SIZE	% SUP	FILL ANGLE	COUPLING SIZE	% SUP	FILL ANGLE	COUPLING SIZE	% SUP	FILL ANGLE		COUPLING SIZE	% SUP	FILL ANGLE	COUPLING SIZE	% SUP	FILL ANGLE
1.00				185	5.5	76				185	3.7	73				185	2.6	70				185	1.9	65	1.00
1.25				185	5.9	72				185	3.7	69				185	2.9	65				185	2.2	58	1.25
1.50				185	5.6	69				185	4.3	65				185	3.2	60				235	2.3	80	1.50
1.75				185	7.4	65				185	4.7	60				185	3.7	50				235	2.0	77	1.75
2.00				185	7.1	60				185	5.6	53				235	3.3	79				235	1.8	75	2.00
2.50				235	5.5	80				235	3.7	77				235	2.7	75				235	1.7	71	2.50
3.00				235	6.3	78				235	3.4	74				235	2.7	72				235	1.8	67	3.00
4.00				235	5.6	73				235	3.5	69				235	3.0	66				235	2.1	59	4.00
5.00				235	5.7	69				235	4.2	64				235	3.3	59				270	1.9	66	5.00
6.25				270	3.5	73				270	2.6	68				270	2.4	66				270	2.1	61	6.25
7.50				270	3.3	69				270	3.1	65				270	2.8	62				270	2.3	57	7.50
8.75				270	4.1	66				270	3.5	62				270	3.2	59				320	1.5	71	8.75
10.0				270	4.7	63				270	4.1	59				270	3.4	54				320	1.7	69	10.0
12.5				270	7.4	59				270	4.8	51				320	2.2	69				320	1.9	64	12.5
15.0	370	2.9	98	320	3.2	72	370	1.3	89	320	2.6	68	370	1.2	83	320	2.5	65	370	0.9	76	320	2.2	61	15.0
17.5	370	2.0	91	320	3.3	69	370	1.5	83	320	3.1	65	370	1.1	78	320	2.7	62	370	0.9	72	320	2.3	57	17.5
20.0	370	1.9	86	320	3.8	66	370	1.4	79	320	3.5	63	370	1.1	74	320	3.0	59	370	0.9	69	320	2.2	50	20.0
22.5	370	1.8	81	320	4.4	64	370	1.4	75	320	4.0	60	370	1.2	71	320	3.4	56	370	1.1	67	370	1.7	67	22.5
25.0	370	1.9	78	320	5.4	62	370	1.5	73	320	4.6	58	370	1.3	69	320	3.3	50	370	1.2	65	370	1.9	65	25.0
27.5	370	1.9	75	370	3.4	75	370	1.6	71	320	4.7	54	370	1.4	67	370	2.2	67	370	1.3	63	370	2.0	63	27.5
30.0	370	2.0	73	370	3.4	73	370	1.7	69	370	2.6	69	370	1.6	66	370	2.4	66	370	1.5	61	370	2.1	61	30.0
35.0	370	2.2	70	370	3.1	70	370	2.1	66	370	3.0	66	370	2.0	63	370	2.7	63	370	1.7	58	370	2.2	58	35.0
40.0	370	2.6	67	370	3.8	67	370	2.5	63	370	3.3	63	370	2.4	60	370	3.0	60	370	1.8	53	370	2.3	53	40.0
45.0	370	3.1	65	370	4.2	65	370	2.9	61	370	3.8	61	370	2.6	57	370	3.3	57	1420	1.2	66	1420	1.9	66	45.0
50.0	370	3.5	63	370	5.1	63	370	3.2	59	370	4.5	59	370	2.7	53	370	3.5	53	1420	1.3	64	1420	2.0	64	50.0
55.0	370	4.0	61	1420	3.4	74	370	3.5	56	370	4.8	56	1420	1.6	66	1420	2.3	66	1420	1.4	62	1420	2.1	62	55.0
60.0	1420	2.1	72	1420	3.4	72	370	3.5	51	370	4.7	51	1420	1.8	65	1420	2.6	65	1420	1.6	60	1420	2.1	60	60.0
67.5	1420	2.2	69	1420	3.2	69	1420	2.2	65	1420	3.0	65	1420	2.0	62	1420	2.7	62	1420	1.8	57	1420	2.2	57	67.5
75.0	1420	2.6	67	1420	3.8	67	1420	2.4	63	1420	3.3	63	1420	2.4	60	1420	2.9	60	1420	1.8	53	1420	2.3	53	75.0
87.5	1420	3.2	64	1420	4.4	64	1420	3.0	60	1420	3.9	60	1420	2.6	56	1420	3.4	56	1480	1.2	66	1480	1.8	66	87.5
100.0	1420	3.8	62	1480	3.3	75	1420	3.4	57	1420	4.7	57	1480	1.4	68	1480	2.2	68	1480	1.3	63	1480	2.0	63	100.0
112.5	1480	2.0	72	1480	3.2	72	1420	3.6	52	1420	4.9	52	1480	1.7	65	1480	2.5	65	1480	1.5	61	1480	2.1	61	112.5
125.0	1480	2.1	70	1480	3.0	70	1480	2.0	66	1480	2.8	66	1480	1.9	63	1480	2.6	63	1480	1.7	59	1480	2.2	59	125.0
137.5	1480	2.4	68	1480	3.5	68	1480	2.3	65	1480	3.2	65	1480	2.1	61	1480	2.8	61	1480	1.8	56	1480	2.3	56	137.5
150.0	1480	2.7	67	1480	4.0	67	1480	2.5	63	1480	3.4	63	1480	2.4	60	1480	3.1	60	1480	1.8	51	1480	2.2	51	150.0
175.0	1480	3.3	64	1480	4.6	64	1480	3.1	60	1480	4.2	60	1480	2.6	55	1480	3.4	55	1584	0.9	72	1584	1.6	72	175.0
200.0	1480	3.9	61	1584	7.3	83▲	1480	3.4	56	1584	3.3	78	1584	1.2	74	1584	2.0	74	1584	1.0	69	1584	1.7	69	200.0
225.0	1584	1.9	81	1584	4.8	79▲	1480	3.6	50	1584	2.5	75	1584	1.2	71	1584	2.2	71	1584	1.1	66	1584	1.8	66	225.0
250.0	1584	1.9	77	1584	4.3	77	1584	1.5	72	1584	2.5	72	1584	1.3	69	1584	2.2	69	1584	1.2	64	1584	1.9	64	250.0
275.0	1584	2.0	75	1584	3.5	75	1584	1.5	70	1584	2.4	70	1584	1.5	67	1584	2.3	67	1584	1.4	63	1584	2.1	63	275.0
300.0	1584	2.0	72	1584	3.2	72	1584	1.7	68	1584	2.6	68	1584	1.7	65	1584	2.5	65	1584	1.5	61	1584	2.1	61	300.0
325.0	1584	2.1	71	1584	3.2	71	1584	1.9	67	1584	2.8	67	1584	1.9	64	1584	2.7	64	1584	1.6	59	1584	2.2	59	325.0
350.0	1584	2.2	69	1584	3.2	69	1584	2.2	65	1584	3.0	65	1584	2.0	62	1584	2.7	62	1584	1.8	57	1584	2.2	57	350.0
375.0	1584	2.5	68	1584	3.6	68	1584	2.4	64	1584	3.2	64	1584	2.2	61	1584	2.9	61	1584	1.8	55	1584	2.3	55	375.0
400.0	1584	2.7	67	1584	3.6	65●	1584	2.6	63	1584	3.4	63	1584	2.5	60	1584	3.1	60	1584	1.8	51	1584	2.2	51	400.0
425.0	1584	2.9	65	1660	3.9	77●	1584	2.8	62	1660	2.4	74	1584	2.5	58	1584	3.2	58	1660	1.1	66	1660	1.8	66	425.0
450.0	1584	3.1	64	1660	2.8	75●	1584	3.0	61	1660	2.5	73	1584	2.6	56	1584	3.3	56	1660	1.2	65	1660	1.9	65	450.0
475.0	1660	1.9	76	1660	3.8	76	1584	3.0	59	1660	2.6	72	1584	2.6	54	1660	2.1	68	1660	1.3	64	1660	2.0	64	475.0
500.0	1660	2.0	75	1660	3.4	75	1660	1.5	70	1660	2.4	70	1584	2.6	51	1660	2.2	67	1660	1.4	63	1660	2.0	63	500.0
550.0	1660	2.1	73				1660	1.7	68	1660	2.6	68	1660	1.7	65	1660	2.5	65	1660	1.5	61	1660	2.1	61	550.0
600.0	1660	2.1	71				1660	1.9	67	1660	2.8	67	1660	1.9	64	1660	2.7	64	1660	1.6	59	1660	2.2	59	600.0
650.0	1660	2.3	69				1660	2.2	65	1760	4.0	81▼	1660	2.0	62	1660	2.7	62	1660	1.8	57	1660	2.2	57	650.0
700.0	1660	2.5	68				1660	2.4	64	1760	3.6	80	1660	2.3	61	1760	1.8	75	1660	1.8	54	1660	2.3	54	700.0
750.0	1760	2.0	85				1760	1.4	78	1760	3.4	78	1660	2.4	59	1760	2.0	74	1660	1.8	50	1660	2.2	50	750.0
800.0	1760	1.9	82				1760	1.5	76	1760	3.0	76	1760	1.2	72	1760	2.1	72	1760	1.0	67	1760	1.7	67	800.0
850.0	1760	1.8	80				1760	1.4	74	1760	2.4	74	1760	1.3	71	1760	2.2	71	1760	1.1	66	1760	1.8	66	850.0
900.0	1760	1.9	78	2870	3.4	83	1760	1.5	73	1760	2.4	73	1760	1.2	69	1760	2.1	69	1760	1.2	65	1760	1.9	65	900.0
950.0	1760	1.9	77	2870	3.4	83	1760	1.6	72	1760	2.6	72	1760	1.3	68	1760	2.1	68	1760	1.3	64	1760	2.0	64	950.0
1000.0	1760	1.9	75	2870	3.5	81	1760	1.6	71	2870	3.2	78	1760	1.4	67	1760	2.2	67	1760	1.3	63	1760	2.0	63	1000.

# General Duty (Other than Belt Conveyors) Quick Selection Table 1170 rpm input speed

Load Horse-power	GENERAL DUTY START FACTOR †																					Load Horse-power			
	140%						170%						200%						250%						
	HFD			HFN/HFR*			HFD			HFN/HFR*			HFD			HFN/HFR*			HFD				HFN/HFR*		
	COUPLING SIZE	% SLIP	FILL ANGLE	COUPLING SIZE	% SLIP	FILL ANGLE	COUPLING SIZE	% SLIP	FILL ANGLE	COUPLING SIZE	% SLIP	FILL ANGLE	COUPLING SIZE	% SLIP	FILL ANGLE	COUPLING SIZE	% SLIP	FILL ANGLE	COUPLING SIZE	% SLIP	FILL ANGLE		COUPLING SIZE	% SLIP	FILL ANGLE
1.00				235	6.0	86						235	4.1	82								235	3.0	79	1.00
1.25				235	5.9	80						235	3.9	78								235	2.9	76	1.25
1.50				235	6.3	79						235	3.4	75								235	2.4	72	1.50
1.75				235	4.7	75						235	3.7	73								235	2.6	70	1.75
2.00				235	5.3	74						235	3.3	70								235	2.9	67	2.00
2.50				235	5.3	70						235	4.3	66								235	3.2	61	2.50
3.00				235	7.0	66						235	4.5	60								235	3.7	51	3.00
4.00				270	3.3	69						270	3.1	65								270	2.8	62	4.00
5.00				270	4.3	64						270	3.9	60								270	3.3	56	5.00
6.25				270	6.9	60						270	4.8	54								320	2.1	69	6.25
7.50	370	2.9	100	320	3.3	73	370	1.4	91			320	2.5	69	370	1.3	85				320	2.4	66	7.50	
8.75	370	2.2	93	320	3.1	70	370	1.6	85			320	2.9	66	370	1.1	79				320	2.7	63	8.75	
10.0	370	1.9	88	320	3.7	67	370	1.3	80			320	3.3	64	370	1.1	75				320	2.9	60	10.0	
12.5	370	1.8	79	320	4.9	63	370	1.5	74			320	4.3	59	370	1.2	70				320	3.5	54	12.5	
15.0	370	2.0	74	370	3.3	74	370	1.6	70			320	4.7	52	370	1.5	67				370	2.3	67	15.0	
17.5	370	2.2	71	370	3.2	71	370	1.9	67			370	2.8	67	370	1.9	64				370	2.7	64	17.5	
20.0	370	2.4	68	370	3.6	68	370	2.3	64			370	3.2	64	370	2.2	61				370	2.8	61	20.0	
22.5	370	2.9	66	370	4.1	66	370	2.7	62			370	3.6	62	370	2.4	58				370	3.1	58	22.5	
25.0	370	3.3	64	370	4.6	64	370	3.1	60			370	4.2	60	370	2.6	55				370	3.4	55	25.0	
27.5	370	3.8	62	1420	3.4	75	370	3.3	57			370	4.5	57	1420	1.5	67				1420	2.2	67	27.5	
30.0	370	4.1	60	1420	3.5	73	370	3.5	54			370	4.7	54	1420	1.7	65				1420	2.5	65	30.0	
35.0	1420	2.2	69	1420	3.1	69	1420	2.1	66			1420	3.0	66	1420	2.0	62				1420	2.7	62	35.0	
40.0	1420	2.6	67	1420	3.9	67	1420	2.5	63			1420	3.3	63	1420	2.4	60				1420	3.0	60	40.0	
45.0	1420	3.1	65	1420	4.3	65	1420	2.9	61			1420	3.9	61	1420	2.6	57				1420	3.4	57	45.0	
50.0	1420	3.5	62	1420	5.1	62	1420	3.2	58			1420	4.4	58	1420	2.7	52				1420	3.4	52	50.0	
55.0	1420	4.1	61	1480	3.3	74	1420	3.4	55			1420	4.6	55	1480	1.5	67				1480	2.3	67	55.0	
60.0	1480	2.0	72	1480	3.3	72	1420	3.6	51			1420	4.8	51	1480	1.7	65				1480	2.5	65	60.0	
67.5	1480	2.2	70	1480	3.1	70	1480	2.1	66			1480	2.9	66	1480	2.0	63				1480	2.7	63	67.5	
75.0	1480	2.5	68	1480	3.8	68	1480	2.4	64			1480	3.3	64	1480	2.3	61				1480	2.9	61	75.0	
87.5	1480	3.1	65	1480	4.3	65	1480	2.9	61			1480	3.9	61	1480	2.6	57				1480	3.3	57	87.5	
100.0	1480	3.7	62	1480	5.4	62	1480	3.3	58			1480	4.7	58	1480	2.6	50				1480	3.3	50	100.0	
112.5	1584	1.9	82	1584	7.6	82	1480	3.5	53			1480	4.8	53	1584	1.2	72				1584	2.1	72	112.5	
125.0	1584	1.9	79	1584	5.5	79	1584	1.5	73			1584	2.4	73	1584	1.2	70				1584	2.1	70	125.0	
137.5	1584	2.0	76	1584	3.9	76	1584	1.6	71			1584	2.6	71	1584	1.4	68				1584	2.2	68	137.5	
150.0	1584	2.0	74	1584	3.4	74	1584	1.6	69			1584	2.5	69	1584	1.6	66				1584	2.3	66	150.0	
175.0	1584	2.1	70	1584	3.0	70	1584	2.0	66			1584	2.8	66	1584	1.9	63				1584	2.6	63	175.0	
200.0	1584	2.5	68	1584	3.8	68	1584	2.4	64			1584	3.3	64	1584	2.3	61				1584	2.9	61	200.0	
225.0	1584	2.9	65	1584	4.0	65	1584	2.8	62			1584	3.7	62	1584	2.5	58				1584	3.2	58	225.0	
250.0	1584	3.4	63	1584	4.7	63	1584	3.0	59			1584	4.2	59	1584	2.6	54				1584	3.4	54	250.0	
275.0	1584	3.8	61	1660	3.4	74	1584	3.4	57			1584	4.8	57	1660	1.6	66				1660	2.3	66	275.0	
300.0	1660	2.1	72	1660	3.3	72	1584	3.5	53			1660	2.7	68	1660	1.8	65				1660	2.6	65	300.0	
325.0	1660	2.1	70	1660	3.1	70	1660	2.0	66			1660	2.9	66	1660	1.9	63				1660	2.7	63	325.0	
350.0	1660	2.4	69	1660	3.4	69	1660	2.3	65			1660	3.1	65	1660	2.1	62				1660	2.8	62	350.0	
375.0	1660	2.6	67	1660	3.7	67	1660	2.4	63			1660	3.2	63	1660	2.3	60				1660	2.9	60	375.0	
400.0	1660	2.8	66	1660	4.0	66	1660	2.6	62			1660	3.5	62	1660	2.4	59				1660	3.1	59	400.0	
425.0	1660	3.0	65	1660	4.0	63▲	1660	2.9	61			1660	3.8	61	1660	2.5	57				1660	3.3	57	425.0	
450.0	1660	3.3	64	1760	4.4	78▲	1660	3.1	60			1760	2.4	74	1660	2.6	55				1660	3.4	55	450.0	
475.0	1660	3.5	63	1760	5.0	78	1660	3.2	59			1760	2.4	73	1660	2.7	53				1660	3.5	53	475.0	
500.0	1760	1.9	77	1760	4.5	77	1660	3.3	57			1760	2.6	72	1760	1.3	68				1760	2.1	68	500.0	
550.0	1760	2.0	74	1760	3.3	74	1760	1.6	70			1760	2.5	70	1760	1.5	67				1760	2.3	67	550.0	
600.0	1760	2.1	72	1760	3.3	72	1760	1.8	68			1760	2.6	68	1760	1.7	65				1760	2.6	65	600.0	
650.0	1760	2.1	70	1760	3.0	70	1760	2.0	66			1760	2.8	66	1760	1.9	63				1760	2.6	63	650.0	
700.0	1760	2.3	69	1760	3.3	69	1760	2.2	65			1760	3.1	65	1760	2.1	62				1760	2.8	62	700.0	
750.0	1760	2.5	67	2870	3.7	74	1760	2.4	64			2870	3.5	73	1760	2.3	61				1760	3.0	61	750.0	
800.0	1760	2.7	66	2870	3.7	73	1760	2.6	62			2870	3.4	70	1760	2.4	59				2870	3.0	67	800.0	
850.0	2870	4.2	76	2870	3.7	72	1760	2.8	61			2870	3.4	70	1760	2.5	58				2870	3.0	66	850.0	
900.0	◆	◆	◆	2870	3.7	71	2870	3.9	73			2870	3.4	69	1760	2.6	56				2870	3.0	65	900.0	
950.0	◆	◆	◆	2870	3.8	70	2870	3.9	71			2870	3.3	67	2870	3.7	69				2870	3.0	64	950.0	
1000.0	◆	◆	◆	2870	3.8	69	◆	◆	◆			2870	3.3	66	2870	3.7	68				2870	3.1	62	1000.0	
1100.0	◆	◆	◆	◆	◆	◆	◆	◆	◆			2870	3.2	62	◆	◆	◆				2870	3.1	60	1100.0	
1200.0	◆	◆	◆	◆	◆	◆	◆	◆	◆			◆	◆	◆	◆	◆	◆				2870	2.8	52	1200.0	
1300.0	◆	◆	◆	◆	◆	◆	◆	◆	◆			◆	◆	◆	◆	◆	◆				◆	◆	◆	◆	1300.0
1400.0	◆	◆	◆	◆	◆	◆	◆	◆	◆			◆	◆	◆	◆	◆	◆				◆	◆	◆	◆	1400.0
1500.0	◆	◆	◆	◆	◆	◆	◆	◆	◆			◆	◆	◆	◆	◆	◆				◆	◆	◆	◆	1500.0

† Start Factor for General Duty (Other than Belt Conveyors) is the nominal torque applied at the inception of acceleration, expressed as a percent of running load torque.  
 \* Sizes 185/235/270/320/2870 are HFN. Sizes 370/1420/1480 are HFN or HFR depending on mounting arrangement. Sizes 1584/1660/1760/2760 are HFR.  
 ▲ 150% Start Factor.  
 ◆ Refer to Falk.

# General Duty (Other than Belt Conveyors) Quick Selection Table 870 rpm input speed

Load Horse-power	GENERAL DUTY START FACTOR †																		Load Horse-power						
	140%						170%						200%							250%					
	HFD			HFN/HFR*			HFD			HFN/HFR*			HFD			HFN/HFR*				HFD			HFN/HFR*		
	COUPLING SIZE	% SLIP	FILL ANGLE	COUPLING SIZE	% SLIP	FILL ANGLE	COUPLING SIZE	% SLIP	FILL ANGLE	COUPLING SIZE	% SLIP	FILL ANGLE	COUPLING SIZE	% SLIP	FILL ANGLE	COUPLING SIZE	% SLIP	FILL ANGLE		COUPLING SIZE	% SLIP	FILL ANGLE	COUPLING SIZE	% SLIP	FILL ANGLE
1.00				235	4.9	70				235	4.1	66				235	3.2	62				235	2.3	50	1.00
1.25				235	7.5	65				235	4.7	60				235	3.7	50				270	2.1	63	1.25
1.50				270	3.0	70				270	2.8	67				270	2.7	64				270	2.2	59	1.50
1.75				270	3.9	67				270	3.3	64				270	2.9	60				270	2.3	54	1.75
2.00				270	4.2	65				270	3.8	61				270	3.3	57				320	1.6	70	2.00
2.50				270	6.3	60				270	4.7	55				320	2.1	70				320	1.9	66	2.50
3.00				320	3.3	74	370	1.6	93	320	2.5	70	370	1.1	86	320	2.3	66	370	0.8	78	320	2.1	62	3.00
4.00	370	1.8	89	320	3.6	68	370	1.4	81	320	3.2	64	370	1.2	76	320	2.9	61	370	0.9	71	320	2.3	55	4.00
5.00	370	1.8	80	320	4.7	64	370	1.5	75	320	4.2	60	370	1.3	71	320	3.4	55	370	1.1	66	370	1.8	66	5.00
6.25	370	2.0	74	370	3.4	74	370	1.6	69	320	4.9	52	370	1.6	66	370	2.3	66	370	1.4	62	370	2.1	62	6.25
7.50	370	2.2	70	370	3.1	70	370	2.0	66	370	2.9	66	370	2.0	63	370	2.7	63	370	1.7	58	370	2.2	58	7.50
8.75	370	2.7	67	370	4.0	67	370	2.5	63	370	3.4	63	370	2.4	60	370	3.0	60	370	1.8	52	370	2.3	52	8.75
10.00	370	3.2	64	370	4.4	64	370	3.0	60	370	3.9	60	370	2.6	56	370	3.3	56	1420	1.2	65	1420	1.9	65	10.00
12.5	370	4.2	60	1420	3.2	72	370	3.6	54	370	4.9	54	1420	1.7	65	1420	2.5	65	1420	1.5	61	1420	2.1	61	12.5
15.0	1420	2.4	69	1420	3.4	69	1420	2.3	65	1420	3.1	65	1420	2.1	62	1420	2.8	62	1420	1.8	56	1420	2.2	56	15.0
17.5	1420	2.9	66	1420	4.2	66	1420	2.7	62	1420	3.6	62	1420	2.4	58	1420	3.1	58	1480	1.0	67	1480	1.7	67	17.5
20.0	1420	3.4	63	1420	4.9	63	1420	3.1	59	1420	4.3	59	1420	2.7	54	1420	3.5	54	1480	1.2	65	1480	1.9	65	20.0
22.5	1420	4.0	61	1480	3.2	74	1420	3.5	56	1420	4.9	56	1480	1.5	67	1480	2.3	67	1480	1.4	62	1480	2.0	62	22.5
25.0	1480	2.1	72	1480	3.3	72	1480	1.8	68	1480	2.7	68	1480	1.8	65	1480	2.6	65	1480	1.6	60	1480	2.1	60	25.0
27.5	1480	2.2	70	1480	3.1	70	1480	2.0	66	1480	2.9	66	1480	2.0	63	1480	2.7	63	1480	1.7	58	1480	2.2	58	27.5
30.0	1480	2.4	68	1480	3.6	68	1480	2.3	64	1480	3.1	64	1480	2.2	61	1480	2.8	61	1480	1.8	55	1480	2.3	55	30.0
35.0	1480	3.0	65	1480	4.1	65	1480	2.8	61	1480	3.7	61	1480	2.5	58	1480	3.3	58	1584	0.8	73	1584	1.4	73	35.0
40.0	1480	3.6	63	1480	5.2	63	1480	3.2	58	1480	4.4	58	1480	2.6	52	1480	3.4	52	1584	0.9	70	1584	1.6	70	40.0
45.0	1480	4.1	60	1480	6.5	60	1480	3.6	55	1480	4.8	55	1584	1.2	73	1584	2.0	73	1584	1.0	68	1584	1.7	68	45.0
50.0	1584	1.8	80	1584	5.8	80	1584	1.5	74	1584	2.4	74	1584	1.2	70	1584	2.0	70	1584	1.2	66	1584	1.8	66	50.0
55.0	1584	1.9	77	1584	4.4	77	1584	1.6	72	1584	2.6	72	1584	1.3	68	1584	2.1	68	1584	1.3	64	1584	2.0	64	55.0
60.0	1584	1.9	74	1584	3.2	74	1584	1.6	70	1584	2.5	70	1584	1.5	67	1584	2.3	67	1584	1.4	62	1584	2.0	62	60.0
67.5	1584	2.1	72	1584	3.4	72	1584	1.8	68	1584	2.7	68	1584	1.8	64	1584	2.5	64	1584	1.6	60	1584	2.1	60	67.5
75.0	1584	2.2	69	1584	3.2	69	1584	2.1	66	1584	3.0	66	1584	2.0	62	1584	2.7	62	1584	1.8	58	1584	2.3	58	75.0
87.5	1584	2.7	66	1584	3.9	66	1584	2.6	63	1584	3.5	63	1584	2.3	59	1584	3.0	59	1584	1.8	50	1584	2.2	50	87.5
100.0	1584	3.3	64	1584	4.6	64	1584	3.1	60	1584	4.1	60	1584	2.2	55	1584	3.4	55	1660	1.2	64	1660	1.9	64	100.0
112.5	1584	3.8	61	1660	3.3	74	1584	3.4	57	1584	4.7	57	1660	1.6	66	1660	2.3	66	1660	1.4	62	1660	2.1	62	112.5
125.0	1660	2.0	71	1660	3.1	71	1584	3.5	52	1584	4.8	52	1660	1.8	64	1660	2.5	64	1660	1.6	60	1660	2.1	60	125.0
137.5	1660	2.2	69	1660	3.1	69	1660	2.1	66	1660	3.0	66	1660	2.0	63	1660	2.8	63	1660	1.8	58	1660	2.3	58	137.5
150.0	1660	2.5	68	1660	3.7	68	1660	2.4	64	1660	3.2	64	1660	2.2	61	1660	2.9	61	1660	1.9	55	1660	2.4	55	150.0
175.0	1660	3.1	65	1660	4.2	65	1660	2.9	61	1660	3.8	61	1660	2.6	57	1660	3.3	57	1760	1.1	67	1760	1.7	67	175.0
200.0	1660	3.6	62	1660	5.3	62	1660	3.2	58	1660	4.5	58	1660	2.7	51	1660	3.4	51	1760	1.2	65	1760	2.0	65	200.0
225.0	1760	2.0	74	1760	3.3	74	1660	3.6	54	1660	4.9	54	1760	1.5	67	1760	2.3	67	1760	1.4	62	1760	2.0	62	225.0
250.0	1760	2.1	72	1760	3.3	72	1760	1.8	68	1760	2.7	68	1760	1.8	65	1760	2.6	65	1760	1.6	60	1760	2.1	60	250.0
275.0	1760	2.2	70	1760	3.1	70	1760	2.1	66	1760	2.9	66	1760	2.0	63	1760	2.7	63	1760	1.7	58	1760	2.2	58	275.0
300.0	1760	2.4	68	1760	3.6	68	1760	2.3	64	1760	3.2	64	1760	2.2	61	1760	2.8	61	1760	1.8	55	1760	2.3	55	300.0
325.0	1760	2.7	66	1760	3.8	66	1760	2.6	63	1760	3.4	63	1760	2.3	59	1760	3.0	59	1760	1.8	51	1760	2.2	51	325.0
350.0	1760	3.0	65	1760	4.1	65	1760	2.8	61	1760	3.7	61	1760	2.6	58	1760	3.3	58	2870	3.4	69	2870	2.5	60	350.0
375.0	1760	3.3	64	1760	4.6	64	1760	3.1	60	1760	4.1	60	1760	2.6	55	1760	3.4	55	2870	3.3	65	2870	2.5	57	375.0
400.0	1760	3.5	62	1760	5.1	62	1760	3.2	58	1760	4.4	58	1760	2.7	52	1760	3.4	52	2870	3.2	63	2870	2.5	55	400.0
425.0	1760	3.9	61	2870	3.6	68	1760	3.5	57	1760	4.8	57	2870	3.9	49	2870	2.9	60	2870	3.0	59	2870	2.5	52	425.0
450.0	1760	4.1	60	2870	3.7	67	1760	3.5	54	1760	4.7	54	2870	3.7	66	2870	2.9	58	2870	2.0	56	2870	2.6	51	450.0
475.0	2870	4.1	69	2870	3.7	66	1760	3.6	51	2870	3.4	62	2870	3.7	65	2870	2.9	56	2870	2.4	54	2870	2.8	48	475.0
500.0	2870	4.1	67	2870	3.7	64	2870	3.9	65	2870	3.4	61	2870	3.8	64	2870	2.9	54	2870	2.7	53	2870	3.0	46	500.0
550.0	2870	4.2	65	2870	3.8	62	2870	4.0	63	2870	3.2	55	2870	3.0	56	2870	3.1	50	2870	3.3	49	2870	3.2	45	550.0
600.0	2870	4.1	61	2870	3.8	59	2870	3.9	60	2870	3.3	53	2870	3.5	54	2870	3.4	47	2870	3.7	45	2870	3.5	41	600.0
650.0	2870	4.1	58	2870	3.8	57	2870	4.0	57	2870	3.6	50	2870	3.9	51	2870	4.5	45							650.0
700.0	◆	◆	◆				2870	4.3	54	2870	3.8	47	2870	4.2	47	2870	3.9	44							700.0
750.0	◆	◆	◆				◆	◆	◆				◆	◆	◆			◆	◆						750.0
800.0							◆	◆	◆				◆	◆	◆			◆	◆						800.0
900.0							◆	◆	◆				◆	◆	◆			◆	◆						900.0
1000.0																									1000.0
1125.0																									1125.0
1250.0																									1250.0

† Start Factor for General Duty (Other than Belt Con

# HFN20 Gear Coupling Mount (Non Delay Fill)

Flex half of Type G gear coupling at input & output, with gap discs, for horizontal mounting. Type G gear coupling hubs furnished interference fit, no setscrew, unless specified otherwise. The fluid coupling drops in or out when gear coupling sleeves are unbolted and retracted.

Availability by Coupling Size & Type

Type	Description	185	235	270	320	370	1420	1480
HFN20	Non Delay Fill	X	X	X	X	X	X	X

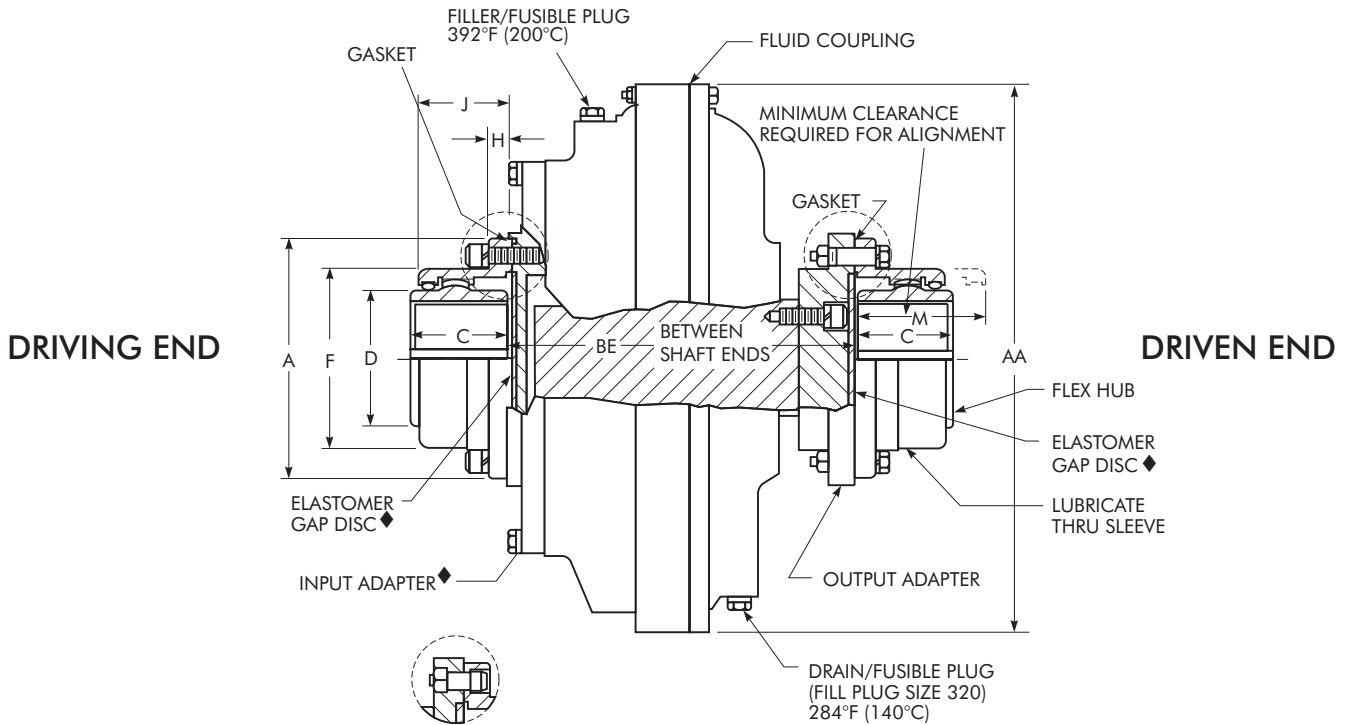

SIZE 185HFN10 - 370HFN10 (SHROUDED BOLTS)  
FURNISHED ONLY WHEN SPECIFIED ON THE ORDER

CPLG SIZE ★	Cplg Weight lb No Bore & W/O Fluid	Allow Speed rpm	Dimensions – Inches										Maximum Bore †			Lube Wt Per Gear Cplg Half-lb	WR <sup>2</sup> (lb-in <sup>2</sup> ) ■			CPLG SIZE ★
			A	C	D	F	H	J	M	AA	BE	Shaft Coupling Type G20			Input		Output	Fluid @ Max Fill		
												Size	Square Key	Rect • Key						
185HF	31	1800	4.56	1.69	2.70	3.30	.55	1.53	2.90	8.86	6.10	1010♦	1.875	2.125	.05	85	20	13.7	185HF	
235HF	62	1800	6.00	1.94	3.40	4.14	.75	1.88	3.20	10.83	7.61	1015	2.375	2.750	.08	232	64	34.2	235HF	
270HF	77	1800	6.00	1.94	3.40	4.14	.75	1.88	3.20	12.40	8.43	1015	2.375	2.750	.08	490	106	103	270HF	
320HF	97	1800	6.00	1.94	3.40	4.14	.75	1.88	3.20	14.37	8.80	1015	2.375	2.750	.08	907	181	191	320HF	
370HF	185	1800	8.38	3.03	5.14	6.10	.86	2.82	4.30	16.73	9.94	1025	3.625	4.000	.25	1,930	445	393	370HF	
1420HF	235	1800	8.38	3.03	5.14	6.10	.86	2.82	4.30	18.70	11.14	1025	3.625	4.000	.25	3,200	721	820	1420HF	
1480HF	300	1800	9.44	3.59	6.00	7.10	.86	3.30	4.30	21.65	12.68	1030	4.125	4.750	.40	5,630	1,504	1,505	1480HF	

★ Fluid couplings are offered for horizontal mounting as shown. Consult Falk for other mounting arrangements. Dimensions are for reference only and subject to change without notice unless certified.

† Type G couplings are furnished with an average INTERFERENCE FIT of .0005" per inch of shaft diameter, without setscrew, unless otherwise specified. Maximum bore capacity is REDUCED when INTERFERENCE FIT with a setscrew OVER the keyway is specified. Refer to Falk publication 427-105 for allowable bores.

• Replace square shaft key with standard rectangular key for use with these bores. CHECK KEY STRESSES.

■ Equivalent mass moment values shown apply only to the fluid coupling with adapters (gear coupling halves not included). Refer to Page 31 for fluid WR<sup>2</sup> multipliers for other than maximum fill.

♦ For Size 185HFN, the 1010G flex half at the driving end mounts directly to the fluid coupling. The input adapter, and driving and driven end gap discs, are not required.

# HF20 Gear Coupling Mount (with Delay Fill Chamber)

Flex half of Type G20 (exposed bolt) gear coupling at input & output, with gap discs, for horizontal mounting. Type G gear coupling hubs furnished interference fit, no setscrew, unless specified otherwise. The fluid coupling drops in or out when gear coupling sleeves are unbolted and retracted.

Type	Description	Availability By Coupling Size & Type				
		370	1420	1480	1584	1660
HFD20	Delay Fill	X	X	X	X	X
HFDD20	Extended Delay Fill		X	X	X	X
HFR20	Inactive Delay Fill				X	X

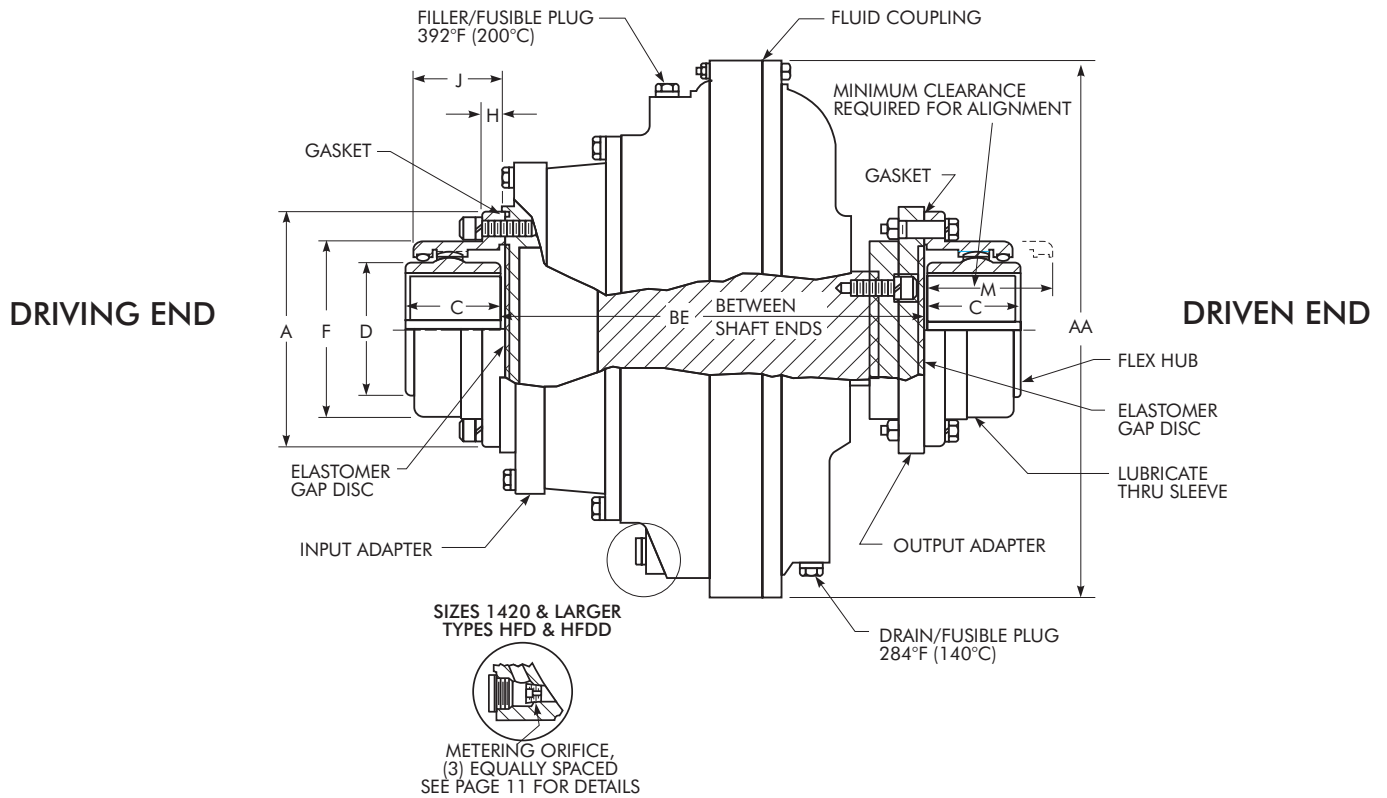

CPLG SIZE ★	Cplg Weight lb No Bore & W/O Fluid		Allow speed rpm	Dimensions – Inches										Maximum Bore †			Lube Wt Per Gear Cplg Half-lb	WR <sup>2</sup> (lb-in <sup>2</sup> ) ■						CPLG SIZE ★
	HFD HFR	HFDD		A	C	D	F	H	J	M	AA	BE			Input	Output		Fluid @ Max Fill						
												HFD HFR	HFDD	Size				Square Key	Rect Key ◆	HFD HFR	HFDD	HFD	HFR	
												HFD HFR	HFDD	Size	Square Key	Rect Key ◆		HFD HFR	HFDD	HFD	HFR	HFDD		
<b>370HF</b>	156	N/A	1800	7.00	2.44	4.14	4.98	0.75	2.34	4.30	16.73	12.69	N/A	1020	2.875	3.250	0.13	1,910	N/A	358	478	N/A	N/A	<b>370HF</b>
<b>1420HF</b>	237	246	1800	8.38	3.03	5.14	6.10	0.86	2.82	4.30	18.70	14.38	17.49	1025	3.625	4.000	0.25	3,080	3,240	740	990	N/A	925	<b>1420HF</b>
<b>1480HF</b>	340	353	1800	9.44	3.59	6.00	7.10	0.86	3.30	4.30	21.65	16.16	19.58	1030	4.125	4.750	0.40	5,700	6,030	1,550	1,980	N/A	1,950	<b>1480HF</b>
<b>1584HF</b>	570	592	1500	11.00	4.19	7.00	8.32	1.12	3.84	5.10	26.38	18.00	21.82	1035	4.875	5.750	0.60	12,150	13,000	3,570	4,955	3,844	5,125	<b>1584HF</b>
<b>1660HF</b>	815	844	1200	12.50	4.75	8.25	9.66	1.12	4.38	5.70	29.92	20.64	24.97	1040	5.750	6.500	1.00	22,900	24,400	6,210	9,225	8,167	9,570	<b>1660HF</b>

★ Fluid couplings are offered for horizontal mounting as shown. Consult Falk for other mounting arrangements. Dimensions are for reference only, and are subject to change without notice unless certified.  
 † Type G couplings are furnished with an average INTERFERENCE FIT of .0005" per inch of shaft diameter, without setscrew, unless otherwise specified. Maximum bore capacity is REDUCED when INTERFERENCE FIT with a setscrew OVER the keyway is specified. Refer to Falk publication 427-105 for allowable bores  
 ■ Equivalent mass moment values shown apply only to the fluid coupling with adapters (gear coupling halves not included). Refer to Page 31 for fluid WR<sup>2</sup> multipliers for other than maximum fill.  
 ◆ To use these maximum bores, a customer furnished rectangular key must replace the standard square key that was supplied with the shaft. CHECK KEY STRESSES.

# HF31, 31-1 Steelflex/Hollow Shaft Mount

Steelflex Type T10 coupling input, hollow shaft output, for horizontal mounting. Hollow shaft is bored to the order, modified clearance fit, with (2) setscrews, one over keyway, one at 90 degrees to keyway. Types HF31, 31-1 diminish the gap required between connected shafts. Type HF31-1 has greater max bore in the hollow shaft, but requires more shaft gap than HF31.

Type	Description	Availability By Coupling Size & Type			
		320	370	1420	1480
HFN31	Non Delay Fill	X			
HFD31, 31-1	Delay Fill		X	X	X
HFR31, 31-1	Inactive Delay Fill		X	X	X

TYPE 31

TYPE 31-1

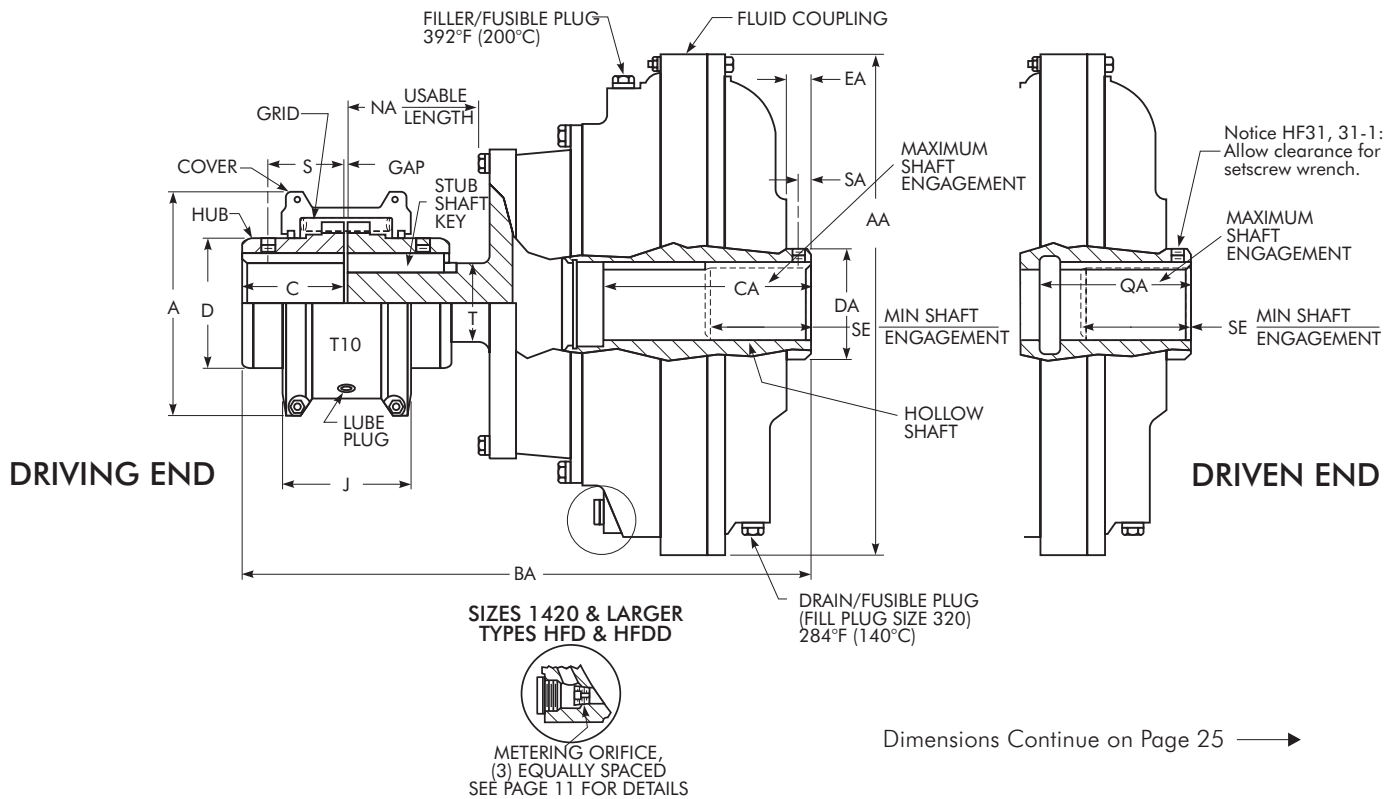

Dimensions Continue on Page 25 →

CPLG SIZE ★	Cplg Weight lb No Bore & W/O Fluid		Allow Speed rpm	Dimensions - Inches																	CPLG SIZE ★	
	HFN	HFD HFR		A	C	D	J	S	AA	BA		CA	DA	EA	IA	NA	QA		SA †	SE (Min)		YA
										HFN	HFD HFR				Fastener Size Types 32 & 32-1		Type 31-1	Type 32-1				
320HF	89	N/A	1800	5.94	2.50	3.00	3.62	2.06	14.37	13.60	N/A	6.06	3.13	0.88	5/8-11 UNC	2.75	N/A	5.00	0.45	3.20	0.75	320HF
370HF	N/A	151	1800	7.62	3.50	4.12	4.56	2.54	16.73	N/A	18.64	7.65	3.52	0.98	3/4-10 UNC	3.83	5.26	5.26	0.45	3.80	0.75	370HF
1420HF	N/A	216	1800	8.38	3.88	4.88	4.81	2.82	18.70	N/A	20.76	8.16	4.12	0.98	7/8-9 UNC	4.21	5.50	5.50	0.45	4.40	1.00	1420HF
1480HF	N/A	320	1800	9.88	4.75	5.59	6.12	N/A	21.65	N/A	24.65	9.01	4.71	1.09	7/8-9 UNC	5.16	6.50	6.50	0.50	5.00	1.12	1480HF
1584HF	N/A	502	1800	10.62	5.00	6.31	6.36	N/A	26.38	N/A	26.74	10.73	5.49	1.00	1 - 8 UNC	5.49	N/A	7.50	N/A	5.80	1.12	1584HF
1660HF	N/A	727	1800	12.12	5.88	7.06	7.54	N/A	29.92	N/A	31.04	12.75	6.28	1.29	1 1/4 - 7 UNC	6.33	N/A	9.00	N/A	6.50	1.12	1660HF
1760HF	N/A	1176	1500	15.12	7.25	10.00	7.92	N/A	34.25	N/A	36.03	15.00	6.68	1.41	1 1/4 - 7 UNC	7.69	N/A	10.50	N/A	7.20	1.25	1760HF
2760HF	N/A	1176	1800†	15.12	7.25	10.00	7.92	N/A	34.25	N/A	36.03	15.00	6.68	1.41	1 1/4 - 7 UNC	7.69	N/A	10.50	N/A	7.20	1.25	2760HF

★ Fluid couplings are offered for horizontal mounting as shown. Refer to Falk for other mounting arrangements. Dimensions are for reference only and are subject to change without notice unless certified.

† Setscrew sizes: Sizes 320HF thru 1420HF are .375-16X.250. Size 1480HF is .500-13X.250.

‡ Special aluminum components.



# HF32, 32-1 Steelflex/Hollow Shaft Mount

Steelflex Type T10 coupling input, hollow shaft output, for horizontal mounting. Hollow shaft secured to driven shaft by axial retention fastener, hollow shaft is bored to the order and includes modified transitional fit, no setscrew. Driven shaft end must be drilled & tapped for retention fastener, and fluid coupling includes Falk furnished spacer (spacer machined to length by Falk based on actual shaft engagement dimension provided by customer. Types HF32, 32-1 diminish the gap required between connected shafts. Type HF32-1 has greater max bore in the hollow shaft, but requires more shaft gap than HF32.

Type	Description	Availability By Coupling Size & Type						
		320	370	1420	1480	1584	1660	1760 2760
<b>HF32, 32-1</b>	Non Delay Fill	X						
<b>HFD32, 32-1</b>	Delay Fill		X	X	X	X	X	X
<b>HFR32, 32-1</b>	Inactive Delay Fill		X	X	X	X	X	X

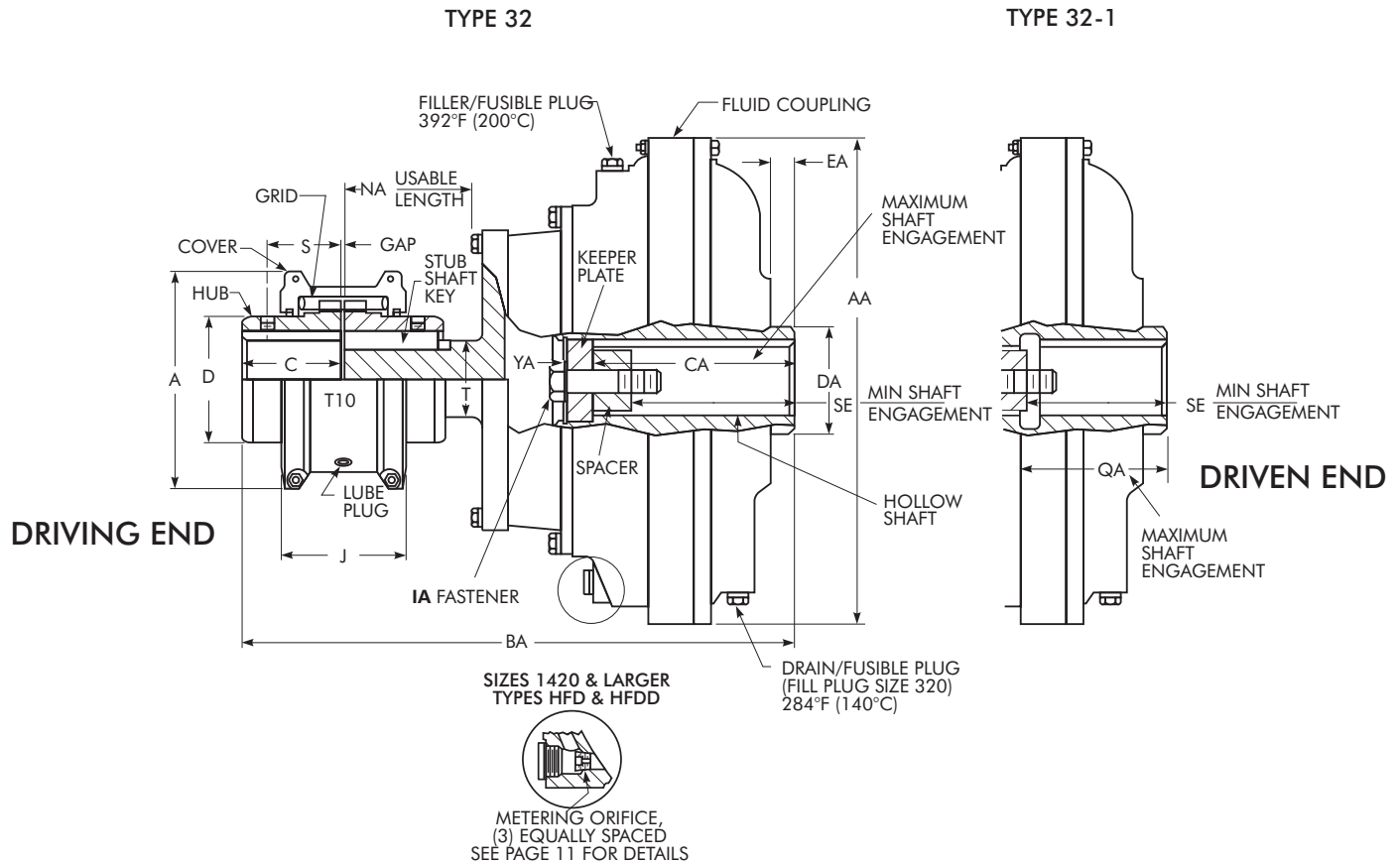

CPLG SIZE ★	Stub Shaft		Maximum Bore											WR <sup>2</sup> (lb-in <sup>2</sup> ) ■				CPLG SIZE ★	
	T	Key	Shaft Coupling †				Hollow Shaft •							Input	Output	Fluid @ Max Fill			
			Gap	Type T10		Type 31•		Type 31-1•		Type 32•		Type 32-1•				HFN HFR	HFD		
				Size	Sq Key	Rect Key ‡	Sq Key	Rect Key ‡	Sq Key	Rect Key ‡	Sq Key	Rect Key ‡	Sq Key						Rect Key ‡
<b>320HF</b>	1.875	1/2 x 1/2 x 2 1/4	0.125	1060	2.125	2.375	2.250	2.500	N/A	N/A	2.250	2.500	N/A	2.500	947	143	191.0	N/A	<b>320HF</b>
<b>370HF</b>	2.500	5/8 x 5/8 x 2 3/4	0.125	1080	3.000	3.375	2.250	2.500	2.500	2.875	2.250	2.500	2.500	2.875	1,910	283	393.0	478	<b>370HF</b>
<b>1420HF</b>	3.000	3/4 x 3/4 x 3	0.125	1090	3.500	3.875	2.500	2.875	3.000	3.375	2.500	2.875	3.000	3.375	3,050	570	820.0	990	<b>1420HF</b>
<b>1480HF</b>	3.500	7/8 x 7/8 x 3 3/4	0.188	1100	4.000	4.500	3.000	3.375	3.375	3.750	3.000	3.375	3.375	3.750	5,620	1,260	1,504	1,980	<b>1480HF</b>
<b>1584HF</b>	4.000	1 x 1 x 4	0.188	1110	4.500	5.000	N/A	N/A	N/A	N/A	3.500	3.875	4.000	4.500	12,100	2,900	3,844	4,955	<b>1584HF</b>
<b>1660HF</b>	4.500	1 x 1 x 4 1/2	0.250	1120	5.000	5.750	N/A	N/A	N/A	N/A	4.000	4.500	4.500	5.000	22,830	5,080	8,167	9,225	<b>1660HF</b>
<b>1760HF</b>	4.750	1 1/4 x 1 1/4 x 5 1/2	0.250	1140	7.000	7.250	N/A	N/A	N/A	N/A	4.750	5.500	N/A	5.500	38,750	9,360	14,660	16,230	<b>1760HF</b>
<b>2760HF</b>	4.750	1 1/4 x 1 1/4 x 5 1/2	0.250	1140	7.000	7.250	N/A	N/A	N/A	N/A	4.750	5.500	N/A	5.500	38,750	9,360	14,660	16,230	<b>2760HF</b>

★ Fluid couplings are offered for horizontal mounting as shown. Refer to Falk for other mounting arrangements. Dimensions are for reference only and are subject to change without notice unless certified.

† Unless otherwise specified, Sizes 1060T10 thru 1090T10 will be furnished for CLEARANCE FIT with a setscrew OVER the keyway, and Sizes 1100T10 and larger will be furnished for INTERFERENCE FIT without setscrew. Maximum bore capacities of Type T10 coupling hubs are REDUCED when INTERFERENCE FIT with a setscrew OVER the keyway is specified. Refer to Falk publication 427-105 for allowable bores.

‡ To utilize these maximum bores, a customer furnished rectangular key must replace the standard square key that was supplied with the shaft. CHECK KEY STRESSES.

• Types 31 & 31-1 hollow shafts are furnished for a modified CLEARANCE FIT with one setscrew over the keyway and one setscrew at 90° to the keyway. Types 32 & 32-1 hollow shafts are furnished with modified TRANSITIONAL FIT, no setscrew.

■ Equivalent mass moment values shown apply only to the fluid coupling (without bore), with stub shaft (flexible coupling not included). Refer to Page 31 for fluid WR<sup>2</sup> multipliers for other than maximum fill.

# HF25 Disc Coupling Mount

Type FD disc coupling mount with discpack at input & output, for horizontal mounting. A-Hubs furnished interference fit, no setscrew, unless specified otherwise. The fluid coupling drops in or out, in conjunction with discpack/adaptor assemblies.

Type	Description	Availability by Coupling Size & Type						
		370	1420	1480	1584	1660	1760 2760	2870
HFN25	Non Delay Fill							X
HFD25	Delay Fill	X	X	X	X	X	X	X
HFDD25	Extended Delay Fill		X	X	X	X	X	X
HFR25	Inactive Delay Fill	X	X	X	X	X	X	

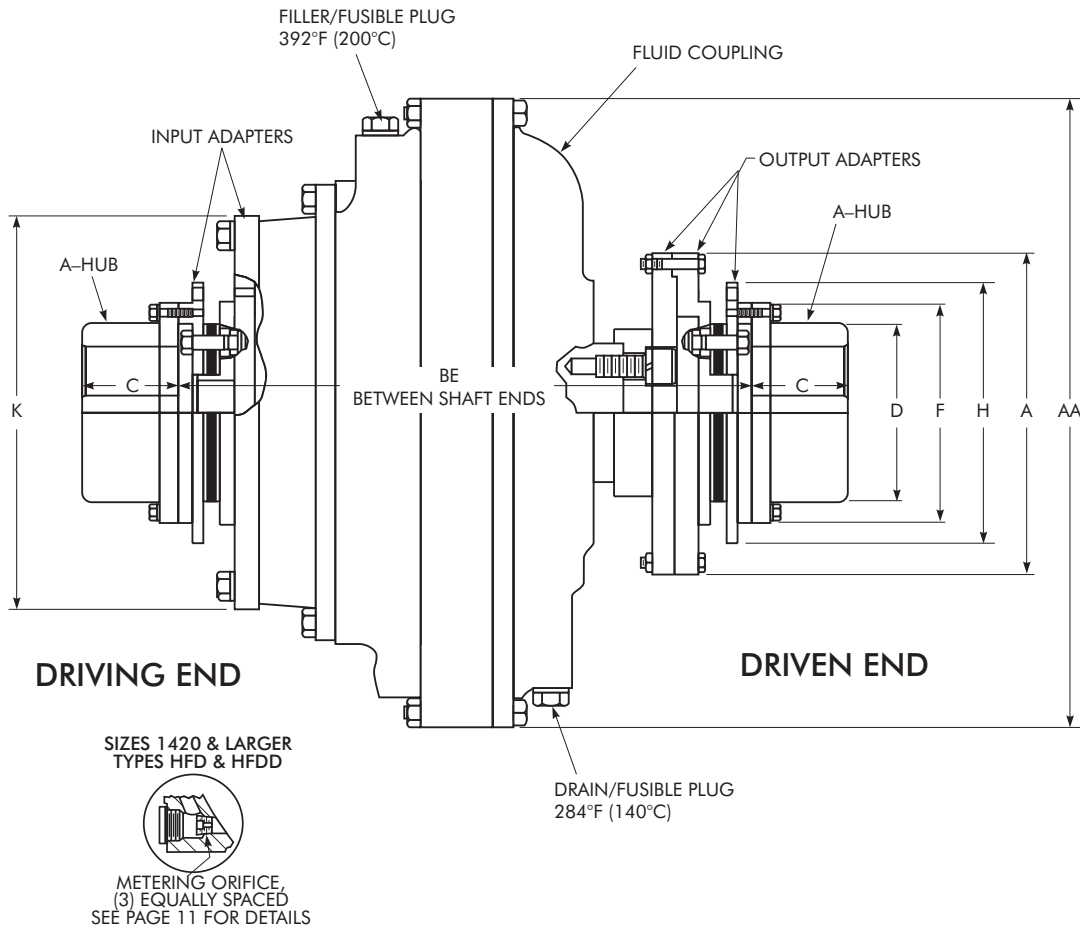

CPLG SIZE ★	Cplg Weight lb No Bore & W/O Fluid		Allow Speed rpm	Dimensions – Inches								Maximum Bore †		WR <sup>2</sup> (lb-in <sup>2</sup> ) ‡					CPLG SIZE ★		
	HFD HFR	HFDD		A	C	D	F	H	K	AA	BE		Shaft Coupling Type FD		Input		Output	Fluid @ Max Fill			
											HFD HFR	HFDD	Size	Sq. Key	HFD HFR	HFDD		HFD		HFR	HFDD
<b>370HF</b>	184	N/A	1800	9.50	2.92	5.30	6.60	7.75	10.04	16.73	N/A	<b>190FD06A</b>	3.750	1,870	N/A	650	478	393	N/A	<b>370HF</b>	
<b>1420HF</b>	230	239	1800	9.50	2.92	5.30	6.60	7.75	11.50	18.70	17.12	20.23	3.750	2,850	3,010	827	990	820	925	<b>1420HF</b>	
<b>1480HF</b>	337	350	1800	11.25	3.43	6.30	7.75	9.50	13.28	21.65	19.50	22.92	<b>340FD06A</b>	4.375	5,214	5,545	1,864	1,980	1,504	1,950	<b>1480HF</b>
<b>1584HF</b>	546	568	1800	12.00	3.82	7.10	8.60	10.25	15.24	26.38	22.18	26.00	<b>625FD06A</b>	5.000	11,200	12,050	3,620	4,955	3,844	5,125	<b>1584HF</b>
<b>1660HF</b>	816	845	1800	15.00	4.60	8.34	10.40	12.50	17.80	29.92	25.25	29.58	<b>1080FD06A</b>	5.750	20,815	22,315	7,290	9,225	8,167	9,570	<b>1660HF</b>
<b>1760HF</b>	1177	1219	1500	16.50	5.30	9.60	11.70	13.75	20.34	34.25	28.88	33.72	<b>1700FD06A</b>	7.000	38,520	41,321	14,275	16,230	14,660	15,240	<b>1760HF</b>
<b>2760HF</b>	1177	1219	1800	16.50	5.30	9.60	11.70	13.75	20.34	34.25	28.88	33.72	<b>1700FD06A</b>	7.000	38,520	41,321	14,275	16,230	14,660	15,240	<b>2760HF</b>
<b>2870HF</b>	1685	1758	1500	17.00	5.08	8.38	10.85	13.50	23.60	38.98	31.50	37.09	<b>2500FD08A</b>	5.875							<b>2870HF</b>

★ Fluid couplings are offered for horizontal mounting as shown. Refer to Falk for other mounting arrangements. Dimensions are for reference only and are subject to change without notice unless certified.  
 † Type FD Disc Couplings are furnished with an average INTERFERENCE FIT of .0005" per inch of shaft diameter, without setscrew, unless otherwise specified. Maximum bore capacity is REDUCED when INTERFERENCE FIT with a setscrew OVER the keyway is specified. Refer to Falk publication 427-105 for allowable bores.  
 ‡ Equivalent mass moment values shown apply only to fluid coupling (without bore). Refer to Page 31 for fluid WR<sup>2</sup> multipliers for other than maximum fill.  
 • Maximum bore is for hub with keyway for rectangular key.  
 ■ Special aluminum components.

# HF132 & 132-1 Tschan/Hollow Shaft Mount

Tschan coupling input, hollow shaft output, for horizontal mounting. Hollow shaft secured to driven shaft by axial retention fastener, hollow shaft is bored to the order and includes modified transitional fit, no setscrew. Driven shaft end must be drilled & tapped for retention fastener, and fluid coupling includes Falk furnished spacer (spacer machined to length by Falk based on actual shaft engagement dimension provided by customer). Types HF132, 132-1 permit smallest possible gap between connected shafts. Type HF132-1 has greater max bore in the hollow shaft, but requires more shaft gap than HF132.

Type	Description	Availability by Coupling Size & Type					
		370	1420	1480	1584	1660	1760 2760
<b>HFD132, 132-1</b>	Delay Fill	X	X	X	X	X	X
<b>HFDD132, 132-1</b>	Extended Delay Fill	X	X	X	X	X	X
<b>HF132, 132-1</b>	Inactive Delay Fill	X	X	X	X	X	X

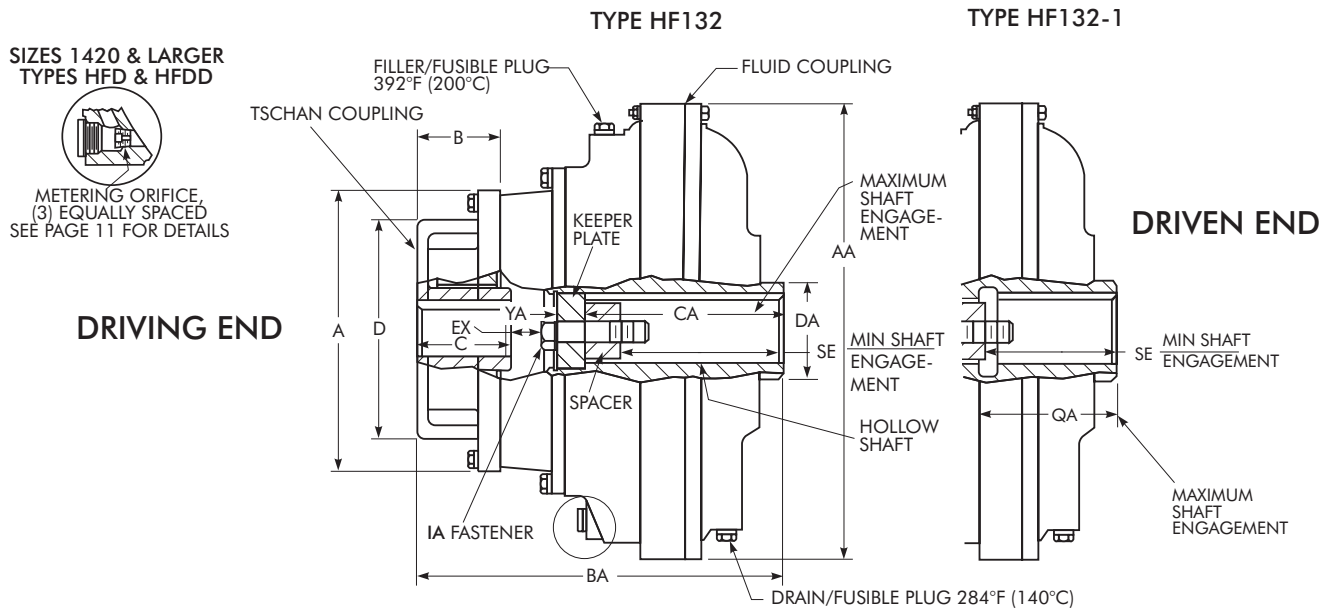

CPLG SIZE ★	Cplg Only, Weight lb No Bore & W/O Fluid		Allow Speed rpm	Dimensions – Inches														CPLG SIZE ★	
	HFD & HFR	HFDD		A	B	C	D	AA	BA		CA	DA	IA Fastener Size	EX		SE (Min)	YA		QA
									HFD & HFR	HFDD				HFD & HFR	HFDD				
<b>370HF</b>	112	N/A	1800	9.92	2.56	3.11†	7.87	16.73	11.41	N/A	6.74	3.52	3/4 - 10 UNC	0.13	N/A	3.80	0.75	4.35	<b>370HF</b>
<b>1420HF</b>	158	167	1800	11.42	2.76	3.54	9.06	18.70	12.88	15.99	7.26	4.12	7/8 - 9 UNC	0.28	3.39	4.40	1.00	4.60	<b>1420HF</b>
<b>1480HF</b>	230	243	1800	13.19	3.35	4.33	10.24	21.65	15.06	18.48	8.00	4.71	7/8 - 9 UNC	0.80	4.22	5.00	1.12	5.50	<b>1480HF</b>
<b>1584HF</b>	392	414	1800	15.16	3.94	5.12	11.81	26.38	17.05	20.87	9.73	5.49	1 - 8 UNC	0.18	4.00	5.80	1.12	6.50	<b>1584HF</b>
<b>1660HF</b>	613	642	1800	17.91	4.84	5.00†	14.17	29.92	20.00	24.33	11.54	6.28	1 1/4 - 7 UNC	1.19	5.52	6.50	1.12	7.79	<b>1660HF</b>
<b>1760HF</b>	829	871	1500	20.24	4.92	5.00†	14.17	34.25	22.45	27.29	13.64	6.68	1 1/4 - 7 UNC	1.41	6.25	7.20	1.25	9.14	<b>1760HF</b>
<b>2760HF</b>	829	871	1800*	20.24	4.92	5.00†	14.17	34.25	22.45	27.29	13.64	6.68	1 1/4 - 7 UNC	1.41	6.25	7.20	1.25	9.14	<b>2760HF</b>

CPLG SIZE ★	Maximum Bore					WR <sup>2</sup> (lb-in <sup>2</sup> ) ♦							CPLG SIZE ★
	Tschan Coupling ‡		Hollow Shaft (transitional fit, no ss)			Input		Output	Fluid @ Max Fill				
	Size	Square Key	Type 132	Type 132-1		HFD & HFR	HFDD		HFR	HFD	HFDD		
			Square Key	Square Key	Rectangular Key ■								
<b>370HF</b>	200	2.38	2.250	2.500	2.875	1,811	N/A	283	393	478	N/A	<b>370HF</b>	
<b>1420HF</b>	230	2.50 •	2.500	3.000	3.375	2,802	3,022	570	820	990	925	<b>1420HF</b>	
<b>1480HF</b>	260	3.38	3.000	3.375	3.750	5,228	5,608	1,260	1,504	1,980	1,950	<b>1480HF</b>	
<b>1584HF</b>	300	3.75	3.500	4.000	4.500	11,448	12,293	2,903	3,844	4,955	5,125	<b>1584HF</b>	
<b>1660HF</b>	360	5.12	4.000	4.500	5.000	21,186	23,990	5,076	8,167	9,225	9,570	<b>1660HF</b>	
<b>1760HF</b>	360	5.12	4.750	N/A	5.500	38,614	39,938	9,252	14,660	16,230	15,240	<b>1760HF</b>	
<b>2760HF</b>	360	5.12	4.750	N/A	5.500	38,614	39,938	9,252	14,660	16,230	15,240	<b>2760HF</b>	

★ Fluid couplings are offered for horizontal mounting as show. Refer to Falk for other mounting arrangements. Dimensions are for reference only and subject to change without notice unless certified.  
 † Non-standard shortened Tschan hub length.  
 ‡ Tschan coupling hubs are furnished with an average INTERFERENCE FIT of .0005' per inch of shaft diameter, unless specified otherwise.  
 • Size 1420HF is available with a 2.88" bore and a .750" x .125" keyway. Falk will furnish a flat key .750" x .500" x 3.5".  
 ■ To use these maximum bores, a customer furnished rectangular key must replace the standard square key that was supplied with the shaft. CHECK KEY STRESSES.  
 ♦ Equivalent mass moment values shown apply only to the fluid coupling (without bore). Refer to Page 31 for fluid WR<sup>2</sup> multipliers for other than maximum fill.  
 \* Special aluminum components.

# HF41 Sheave/Hollow Shaft Mount

Hollow shaft input, QD sheave output, for horizontal mounting. For all sizes below, Falk furnishes specially manufactured QD Adapter (in lieu of QD bushing) to accommodate QD sheave supplied by purchaser. All sizes below are secured to the motor shaft by a collet/collet draw bolt.

Type	Description	Availability By coupling Size & Type				
		185	235	270	320	370
HFN41	Non Delay Fill	X	X	X	X	X
HFD41	Delay Fill					X

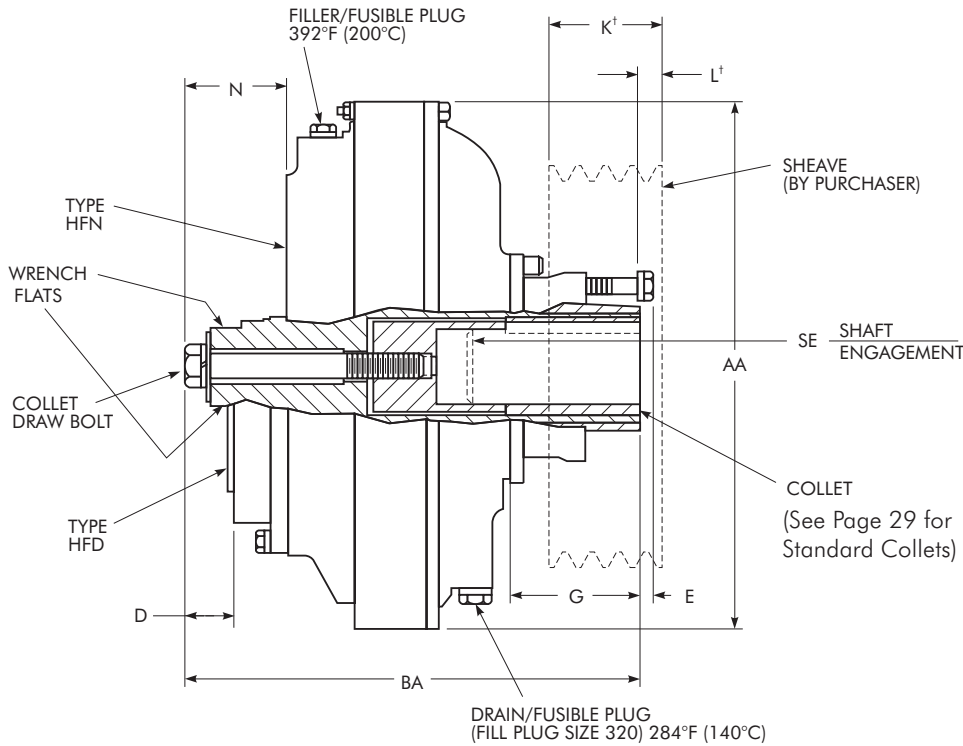

CPLG SIZE ★	Cplg Weight lb No Bore & W/O Sheave, Fluid		Allowable Speed rpm	Sheave Adapter QD *	Dimensions – Inches								CPLG SIZE ★
	HFN	HFD			D	E †	G	N	AA	BA	SE (Min)	SE (Max)	
185HF	22	N/A	1800	SDS	N/A	.26	2.29	.99	8.86	7.69	2.00		185HF
235HF	38	N/A	1800	SK	N/A	.36	2.95	1.31	10.83	9.65	2.50	See Page 29	235HF
270HF	50	N/A	1800	SF	N/A	.42	3.19	1.36	12.40	10.02	2.50		270HF
320HF	81	N/A	1800	E	N/A	.53	4.21	1.93	14.37	12.48	3.12		320HF
370HF	107	114	1800	E	1.45	.53	4.11	3.34	16.73	14.46	3.75		370HF

★ Fluid couplings are offered for horizontal mounting as shown. Refer to Falk for other mounting arrangements. Dimensions are for reference only and are subject to change without notice unless certified.

\* Falk furnishes specially manufactured QD Adapter (in lieu of QD bushing) to accommodate QD sheave supplied by purchaser.

† For Dimensions K and L, refer to sheave tables on Page 29. Dimensions E and L for Sizes 185 thru 370 may vary up to ± .12 inches. For Dimension L, negative value represents dimension to the left of collet face.

FLUID CPLG SIZE	Collet Min Bore ‡ Inches	Collet Max Bore Inches ‡		WR <sup>2</sup> (lb-in <sup>2</sup> ) ♦						FLUID CPLG SIZE
		Square Key	Rectangular ■ Key	Type HFN			Type HFD			
				Input	Output	Fluid @ Max Fill	Input	Output	Fluid @ Max Fill	
185HF	.875	1.000	1.125	12	91	13.7	N/A	N/A	N/A	185HF
235HF	1.125	1.250	1.375	34	217	34.2	N/A	N/A	N/A	235HF
270HF	1.125	1.750	1.875	77	436	103	N/A	N/A	N/A	270HF
320HF	1.375	1.875	2.125	154	873	191	N/A	N/A	N/A	320HF
370HF	1.625	2.125	2.375	299	1,684	393	299	1,718	478	370HF

‡ Minimum bore is the smallest bore to which the collet will be bored. Standard collets (see Page 29). Refer to Falk for non-standard collets.

■ To use these maximum bores, a customer furnished rectangular key must replace the standard square key that was supplied with the shaft. CHECK KEY STRESSES.

♦ Equivalent mass moment values shown apply only to the fluid coupling (without bore), adapter and sheave. Refer to Page 31, Engineering Data, for fluid WR<sup>2</sup> multipliers for other than maximum fill.

# Sheave Selection

## Classical Sheaves (A, B, C)

CPLG SIZE *	K	L †	Pitch Diameter	Grooves	Classical Sheaves	Sheave Adapter (QD) *
185HF	1.38	0.16	4.2-9.0	2	A	SDS
	1.38	0.29	10.6-12.0	2	A	
	0.88	-0.15	4.2-6.4	1	B †	
	1.00	0.16	6.6-13.2	1	B †	
	1.75	0.35	4.2-6.4	2	B †	
	0.88	-0.15	4.6-6.8	1	B	
	1.00	0.16	7.0-13.6	1	B	
1.75	0.35	4.6-6.8	2	B		
235HF	1.38	-0.06	15.0-18.0	2	A	SK
	2.00	0.13	7.0-9.0	3	A	
	2.00	0.26	10.6-18.0	3	A	
	1.00	-0.30	15.0-19.6	1	B †	
	1.75	0.13	6.6-18.0	2	B †	
	2.50	0.63	6.6-18.0	3	B †	
	3.25	1.07	6.6-13.2	4	B †	
	4.00	1.51	6.2, 6.4	5	B †	
	4.75	2.26	6.2, 6.4	6	B †	
	1.00	-0.30	15.4-20.0	1	B	
	1.75	0.13	7.0-18.4	2	B	
	2.50	0.63	7.0-18.4	3	B	
	3.25	1.07	7.0-13.6	4	B	
4.00	1.51	6.6, 6.8	5	B		
4.75	2.26	6.6, 6.8	6	B		
270HF	1.75	0.22	19.6-37.6	2	B †	SF
	2.50	0.72	19.6-29.6	3	B †	
	3.25	1.09	15.0-19.6	4	B †	
	4.00	1.53	7.0-18.0	5	B †	
	4.75	1.90	7.0-18.0	6	B †	
	5.50	2.53	7.0	7	B †	
	6.25	3.28	7.0	8	B †	
	1.75	0.22	20.0-38.0	2	B	
	2.50	0.72	20.0-30.0	3	B	
	3.25	1.09	15.4-20.0	4	B	
	4.00	1.53	7.4-18.4	5	B	
	4.75	1.90	7.4-18.4	6	B	
	5.50	2.53	7.4	7	B	
	6.25	3.28	7.4	8	B	
	1.38	0.09	7.0-24.0	1	C	
	2.38	0.40	7.0-11.0	2	C	
	320HF	2.50	0.34	37.6	3	
3.25		0.71	24.6-37.6	4	B †	
4.00		1.21	19.6-37.6	5	B †	
4.75		1.84	19.6-37.6	6	B †	
5.50		1.96	8.2-15.6	7	B †	
6.25		2.34	8.2-15.6	8	B †	
2.50		0.34	38.0	3	B	
3.25		0.71	25.0-38.0	4	B	
4.00		1.21	20.0-38.0	5	B	
4.75		1.84	20.0-38.0	6	B	
5.50		1.96	8.6-16.0	7	B	
6.25		2.34	8.6-16.0	8	B	
3.38		0.08	8.5-18.0	3	C	
3.38		0.84	20.0, 24.0	3	C	
4.38		0.84	8.5-18.0	4	C	
4.38		1.34	20.0	4	C	
5.38		1.46	8.5-18.0	5	C	
6.38	2.46	8.5	6	C		
370HF	2.50	0.34	37.6	3	B †	E
	3.25	0.71	24.6-37.6	4	B †	
	4.00	1.21	19.6-37.6	5	B †	
	4.75	1.84	19.6-37.6	6	B †	
	5.50	1.96	8.2-15.6	7	B †	
	6.25	2.34	9.0-15.6	8	B †	
	2.50	0.34	38.0	3	B	
	3.25	0.71	25.0-38.0	4	B	
	4.00	1.21	20.0-38.0	5	B	
	4.75	1.84	20.0-38.0	6	B	
	5.50	1.96	8.6-16.0	7	B	
	6.25	2.34	9.4-16.0	8	B	
	3.38	0.08	9.0-18.0	3	C	
	3.38	0.84	20.0, 24.0	3	C	
	4.38	0.84	9.0-18.0	4	C	
	4.38	1.34	20.0	4	C	
	5.38	1.46	9.2-18.0	5	C	

\* † \* See Page 28 for these footnotes.  
† Size A belt in Type B sheave.

## Narrow Sheaves (3V, 5V)

CPLG SIZE *	K	L †	Outside Diameter	Grooves	Narrow Sheaves	Sheave Adapter (QD) *
185HF	.69	-.02	8.0	1	3V	SDS
	.75	.04	10.6	1	3V	
	1.09	.07	6.5-8.0	2	3V	
	1.50	.01	4.5-6.9	3	3V	
	1.91	.38	5.6	4	3V	
235HF	.81	-.37	14.0, 19.0	1	3V	SK
	1.09	-.34	10.6-19.0	2	3V	
	1.50	.07	8.0-14.0	3	3V	
	1.91	.01	6.0-14.0	4	3V	
	2.31	.19	5.3-10.6	5	3V	
	2.72	.23	6.9	6	3V	
	2.72	.66	8.0	6	3V	
	3.53	1.04	6.9	8	3V	
270HF	4.34	1.73	6.9	10	3V	SF
	1.69	.07	7.1-11.8	2	5V	
	1.09	-.32	25.0	2	3V	
	1.50	.09	19.0-33.5	3	3V	
	1.91	.12	19.0, 25.0	4	3V	
	2.31	.28	14.0, 19.0	5	3V	
320HF	2.72	.68	10.6, 14.0	6	3V	E
	3.53	1.25	8.0, 10.6	8	3V	
	4.34	1.68	8.0	10	3V	
	1.69	.09	12.5-21.2	2	5V	
	2.38	.22	7.1-11.8	3	5V	
	1.91	-.13	33.5	4	3V	
	2.31	.15	25.0, 33.5	5	3V	
	2.72	.18	19.0-33.5	6	3V	
	3.53	.74	14.0-25.0	8	3V	
	4.34	1.55	10.6-19.0	10	3V	
370HF	1.69	-.06	23.6	2	5V	E
	2.38	.08	12.5-28.0	3	5V	
	3.06	.08	8.0-16.0	4	5V	
	3.06	.27	18.7, 21.2	4	5V	
	3.75	.46	9.0-16.0	5	5V	
	4.44	.90	8.5-11.8	6	5V	
	5.81	1.77	9.0	8	5V	
	1.91	-.13	33.5	4	3V	
	2.31	.15	25.0, 33.5	5	3V	
	2.72	.18	19.0-33.5	6	3V	

\* † \* See Page 28 for these footnotes.

## Standard Collets (Refer to Falk for Special Collets)

COUPLING SIZE	Collet Part Number	Motor Shaft-in	SE (Max)
185HF	346150	0.875	2.12
	346151	1.125 •	2.88
235HF	346153	1.125	2.88
	346154	1.375 •	3.66
270HF	346155	1.125	2.88
	346156	1.375	3.66
	346157	1.625	4.88
	346158	1.875 •	4.88
320HF	346159	1.375	3.66
	346160	1.625	4.88
	346161	1.875	4.88
	346162	2.125 •	5.64
370HF	346163	1.625	4.88
	346164	1.875	4.88
	346165	2.125	5.64
	346166	2.375 •	6.40
	•	Maximum bore collet requires that standard square shaft key be replaced with customer furnished rectangular key. Service Manual 528-410, Table 2, provides rectangular key sizes. CHECK KEY STRESSES.	

# HF41 Sheave/Hollow Shaft Mount

Hollow shaft input, sheave output, for horizontal mounting. For all sizes below, a specially manufactured sheave is supplied by Falk. Size 1420HF is secured to the motor shaft by a collet/collet draw bolt. Sizes 1480HF & 1584HF are secured to motor shaft by an axial retention fastener, the hollow shaft is bored to the order and includes modified transitional fit, no setscrew, motor shaft end must be drilled & tapped for retention fastener, and coupling includes Falk furnished spacer (spacer to length by Falk based on actual shaft engagement dimension provided by customer).

Type	Description	Availability By Coupling Size & Type		
		1420	1480	1584
HFN41	Non Delay Fill	X	X	X
HFD41	Delay Fill	X	X	X

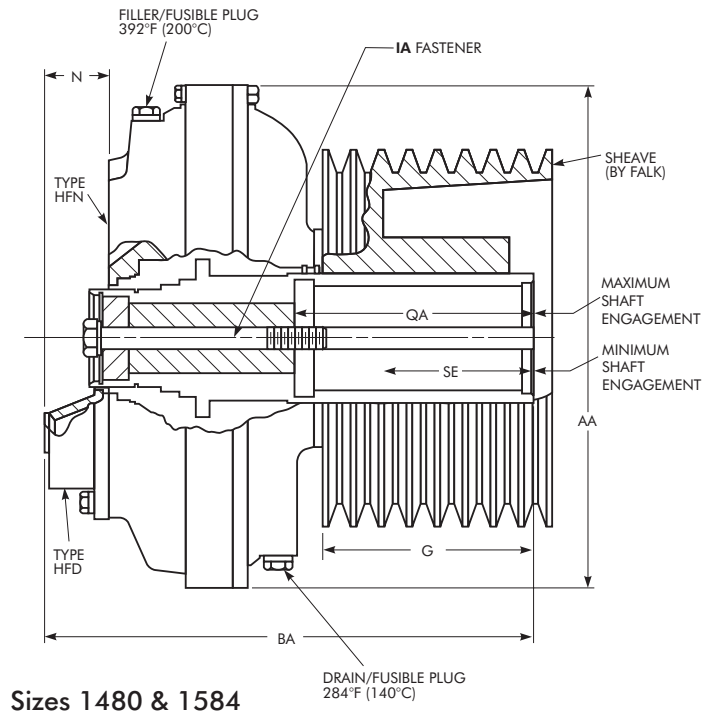
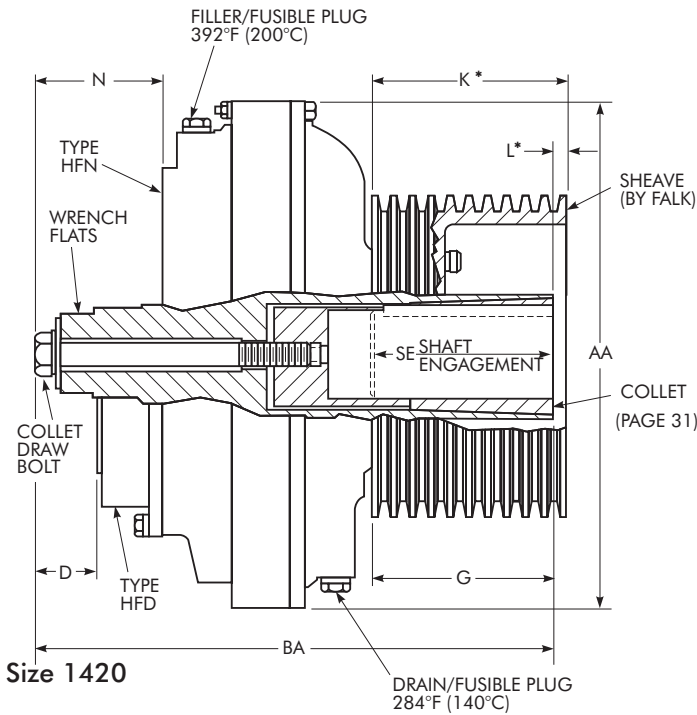

Predesigned Sheaves for Size 1420HF41

Part Number	Description
0428352	9.75" OD, 5V-5 groove
0428231	9.75" OD, 5V-8 groove
0428353	11.8" OD, 5V-5 groove
0428162	11.8" OD, 5V-10 groove

CPLG SIZE ★	Cplg Weight lb No Bore & W/O Sheave, Fluid		Allowable Speed rpm	Dimensions – Inches								CPLG SIZE ★
	HFN	HFD		D	G	N	AA	BA	IA Fastener Size	QA (Max Shaft Engagement)	SE ‡ (Min)	
1420HF	160	168	1800	2.35	6.74	4.71	18.70	19.25			4.38*	1420HF
1480HF	159	172	1800	...	8.07	2.99	21.65	19.80	7/8-9 UNC	8.25	5.62	1480HF
1584HF	276	295	1800	...	8.07	2.91	26.38	21.30	1-8 UNC	10.00	6.25	1584HF

★ Fluid couplings are offered for horizontal mounting as shown. Refer to Falk for other mounting arrangements. Dimensions are for reference only, and are subject to change without notice unless certified.

\* Size 1420HF, see Page 31 for dimensions K, L, and SE (Max).

‡ The preferred engagement between the driving shaft and the hollow bore is twice the diameter of the driving shaft.

FLUID CPLG SIZE	Min Bore	Max Bore – Inches		WR <sup>2</sup> (lb-in <sup>2</sup> ) ♦						FLUID CPLG SIZE
		Square Key	Rectangular Key †	Type HFN			Type HFD			
				Input	Output	Fluid @ Max Fill	Input	Output	Fluid @ Max Fill	
1420HF	1.875 †	3.000	3.375	663	2,460	820	663	2,529	990	1420HF
1480HF	2.062	3.750	4.125	1,230	4,440	1,504	1,230	4,615	1,980	1480HF
1584HF	2.250	4.000	4.375	2,840	9,910	3,844	2,840	10,080	4,955	1584HF

† Minimum bore is the smallest bore to which the collet will be bored. Standard collets (see Page 31). Refer to Falk for non-standard collets.

‡ To use these maximum bores, a customer furnished rectangular key must replace the standard square key that was supplied with the shaft. CHECK KEY STRESSES.

♦ Equivalent mass moment values shown apply only to the fluid coupling (without bore), and sheave. Refer to Page 31, Engineering Data, for fluid WR<sup>2</sup> multipliers for other than maximum fill.

# HF41 Sheave & Collet Data (Sizes 1420 thru 1584HF)

## Classical Sheaves (B, C, D)

CPLG SIZE ★	Pitch Diameter	Grooves	Classical Sheaves
1480HF	11.0 - 15.4	10	B
	9.8 - 10.2	6	C
	11.0 - 14.0	8	C
	12.0 - 15.5	5	D
1584HF	11.0 & 12.4	6	B
	12.4 - 16.0	8	B
	9.8 - 13.0	4	C
	13.0 - 16.0	5	C
	12.0 & 13.0	3	D
	13.0 - 17.0	4	D

★ Dimensions are for reference only, and are subject to change without notice unless certified.

◆ Size 1420 Dimension L, negative value represents dimension to the left of collet face.

## Narrow Sheaves (3V, 5V, 8V)

CPLG SIZE ★	K	L ◆	Outside Diameter	Grooves	Narrow Sheaves
1420HF	3.75	-2.99	9.75 & 11.8	5	5V
	5.81	-.93	9.75	8	5V
	7.19	.45	11.8	10	5V
1480HF	...	...	8.0 & 10.6	15	3V
	...	...	10.6 & 14.0	19	3V
	...	...	8.0 - 10.3	8	5V
	...	...	10.9 - 16.0	10	5V
	...	...	12.5 - 16.0	6	8V
1584HF	...	...	9.75 - 14.0	8	5V
	...	...	13.2 - 16.0	10	5V
	...	...	12.5 - 14.0	6	8V
	...	...	13.2 - 18.0	8	8V
	...	...	...	...	...

## Standard Collets † (Refer to Falk for Special Collets)

CPLG SIZE	Collet Part Number	Motor Shaft-inches	SE (Max)
1420HF	346167	1.875	4.88
	346168	2.125	5.64
	346169	2.375	6.40
	346170	2.875	8.00
	346329	3.375 •	8.44

† Sizes 1480HF & 1584HF do not utilize a collet.

• Maximum bore collet requires that standard square shaft key be replaced with customer furnished rectangular key. Service Manual 528-410, Table 2, provides rectangular key sizes. CHECK KEY STRESSES.

# Engineering Data

## Shaft Diameters and Ratings for NEMA 60 Hertz Motors

Frame Size	T Frames																TS Frames														
	143	145	182	184	213	215	254	256	284	286	324	326	364	365	404	405	444	445	284	286	324	326	364	365	404	405	444	445			
Shaft Dia - Inches	.875	.875	1.125	1.125	1.375	1.375	1.625	1.625	1.875	1.875	2.125	2.125	2.375	2.375	2.875	2.875	3.375	3.375	1.625	1.625	1.875	1.875	1.875	1.875	2.125	2.125	2.375	2.375			
HP @ 1800 RPM	Drip Proof		1	1 1/2	2	3	5	7 1/2	10	15	20	25	30	40	50	60	75	100	125	150	200	25	30	40	50	60	75	100	125	150	200
HP @ 1200 RPM	TEFC		1	1 1/2	2	3	5	7 1/2	10	15	20	25	30	40	50	60	75	100	125	150	25	30	40	50	60	75	100	125	150		
HP @ 900 RPM	Drip Proof & TEFC		3/4	1	1 1/2	2	3	5	7 1/2	10	15	20	25	30	40	50	60	75	100	125	15	20	25	30	40	50	60	75	100	125	
	Drip Proof & TEFC		1/2	3/4	1	1 1/2	2	3	5	7 1/2	10	15	20	25	30	40	50	60	75	100	10	15	20	25	30	40	50	60	75	100	

## Fluid WR<sup>2</sup> Multiplier For Other Than Maximum Fill

Fill Angle°	55	60	65	70	75	80	85	90	95	100
HFN	.98	.94	.90	.86	.81	.78	.74	.69	.63	.59
HFD	.98	.94	.93	.88	.84	.80	.77	.71	.66	.62
HFDD †	...	...	.98	.95	.94	.90	.86	.82	.79	.74

† Maximum fluid fill for Type HFDD is 60°.

## Recommended Keys for Bores with One Key

Shaft Diameters		Key	Shaft Diameters		Key
Over	Thru		Over	Thru	
.437	.562	.125 x .125	2.750	3.250	.750 x .750
.562	.875	.187 x .187	3.250	3.750	.875 x .875
.875	1.250	.250 x .250	3.750	4.500	1.000 x 1.000
1.250	1.375	.312 x .312	4.500	5.500	1.250 x 1.250
1.375	1.750	.375 x .375	5.500	6.500	1.500 x 1.500
1.750	2.250	.500 x .500	6.500	7.500	1.750 x 1.500
2.250	2.750	.625 x .625	7.500	9.000	2.000 x 1.500

# Fluid Fill Angle

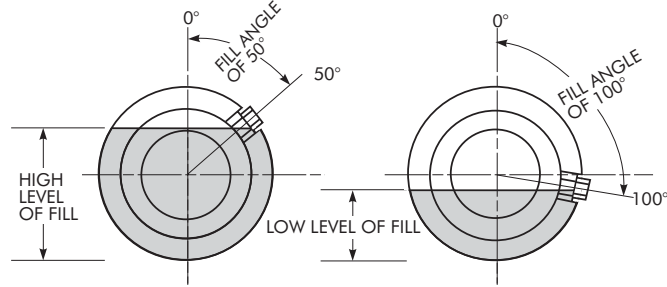

Fluid couplings are shipped without fluid. Fluid is added during installation. The installer adds fluid, obtained locally, and that meets "Recommended Fluids" specifications listed on this page.

When application data (horsepower, rpm, start factor) is provided, the fluid coupling will include an orange sticker with fill angle (degrees), and approximate fill quantity (fluid ounces). If no orange sticker is present, a fill angle may be obtained from the Quick Selection Tables herein (Pages 16-21). Using fill angle as a starting point, approximate fill quantity (fluid ounces) may be obtained from the table below.

Fluid couplings include an angle finder (P/N 1224653) and installation instructions. Remove fill plug, place angle finder on the flat boss at the fill plug location, and rotate coupling to the specified fill angle (degrees from vertical). With the coupling in this position, add fluid until it reaches the lip of the fill hole.

As shown above, a low fill angle (example is 50°) corresponds to a high level of fill. A high fill angle (example is 100°) corresponds to a low level of fill. The level of fill in the coupling determines the start factor, percent slip, starting torque, stall torque, . . . essentially all performance characteristics of the coupling.

After installation and operation, fine-tuning of the fill level may be necessary, based on load readings or other site variables. In general, increasing the fill level (decreasing the fill angle) increases start factor/start torque/stall torque, shortens time required to accelerate the load to operating speed, and reduces percent slip. Reducing the fill level (increasing the fill angle) decreases start factor/start torque/stall torque, increases time required to accelerate the load to operating speed, and increases percent slip.

## Convert Fluid Ounces to Weight (lb)

There are 128 Fluid Ounces per Gallon  
 Weight (lb) = Fluid oz x 0.0648 x specific gravity of the fluid

### Example:

Size 1480HFN @ 70 degree fill angle (See table below)  
 Weight = 413 fluid oz x 0.0648 x 0.87 = 23.3 lb of fluid

# Recommended Fluids †

ISO Viscosity Grade, Petroleum Oils (R & O) . . . . . 46  
 ISO Viscosity Grade, Synthetic Oils . . . . . 32

**Viscosity at 104°F(40°C)** — 46 cSt (215 SSU)

**Viscosity Index** — Equal to or greater than 95.

**Pour Point** — Must be 5°F(3°C) lower than minimum starting temperature.

**Flash Point** — 400°F(204°C) when using 140°C and/or 180°C fusible plugs.

**Flash Point** — 425°F (218°C) when using 200°C fusible plugs at both fill and drain holes.

**Specific Gravity** — 0.87

### Antioxidant and Anti-foaming Additives

#### Petroleum Oils (R & O) For Ambient Temperatures 20°F to 125°F (-6°C to 52°C)

Manufacturer	Fluid
Amoco Oil Company	American Industrial Oil 46
BP Oil Company	HL-C46
Chevron Products Company	Hydraulic Oil AW 46
Exxon Company, USA	Teresstic 46
Mobil Oil Corporation	Mobil Fluid 424
Petra-Canada Products	Harmony 46
Shell Oil Company	Turbo T 46
Texaco Lubricants Company	Rando Oil HD 46
76 Lubricants Company	76 Unax AW 46

#### Petroleum Oils (R & O) For Ambient Temperatures -20°F to 125°F (-28°C to 52°C)

Manufacturer	Fluid
Amoco Oil Company	American Industrial Oil 46
Mobil Oil Corporation	Mobilfluid 424

#### Synthetic Oils and Synthetic Transmission Fluids For Ambient Temperatures -40°F to 125°F (-40°C to 52°C)

Manufacturer	Fluid
Conoco Incorporated	Syncon R&O 32
Exxon Company, USA	Teresstic SHP 32
Mobil Oil Corporation	SHC 624
Texaco Lubricants Company	Pinnacle 32
Mobil Oil Corp.	Synthetic ATF
Chevron	Synthetic All Weather THF
Citgo	Transgard Fluid 250

#### Automatic Transmission Fluids (Dexron or Mercon Oils, etc.) For Ambient Temperatures -40°F to 125°F (-40°C to 52°C)

**NOTICE: Automatic Transmission Fluids below can only be used with two 140°C fusible plugs**

Mobil	Multi-purpose ATF
Texaco (Havoline)	Mercon/Dexron-III or ATF
Citgo	Transgard ATF, Type F

ATF Type A and Type Dexron II, IID, IIE, III, Mercon M-891205 and M-921253

† Refer to Falk for use of fire resistant fluids. Recommended fluids are typical products only, and should not be construed as exclusive recommendations.

## Approximate Fill Quantity (Fluid Ounces)

Fill Angle (Degrees) From Vertical	Types HFN & HFR										Type HFD					Type HFDD					Fill Angle (Degrees) From Vertical	
	COUPLING SIZE																					
	185	235	270	320	370	1420	1480	1584	1660	1760 2760	370	1420	1480	1584	1660	1760 2760	1420	1480	1584	1660		1760 2760
50	34	65	88	142	239	352	524	862	1555	2147	303	440	710	1136	1833	2645	N/A	N/A	N/A	N/A	N/A	50
55	33	63	83	136	233	331	497	835	1481	2012	292	426	663	1096	1762	2492	N/A	N/A	N/A	N/A	N/A	55
60	31	60	78	128	221	311	473	801	1413	1894	276	399	629	1055	1684	2360	524	795	1322	1924	2705	60
65	30	57	73	120	207	291	443	754	1319	1792	257	382	578	977	1569	2164	484	727	1224	1789	2503	65
70	28	53	69	113	192	271	413	700	1234	1640	237	348	531	910	1461	1985	443	663	1130	1650	2300	70
75	26	50	65	105	177	247	385	649	1150	1539	218	328	497	832	1359	1846	406	605	1045	1529	2131	75
80	24	47	61	98	162	230	348	592	1065	1420	200	298	460	751	1248	1701	369	561	964	1403	1961	80
85	22	43	57	90	149	216	321	544	984	1336	185	281	419	693	1150	1600	342	521	896	1295	1809	85
90	20	39	52	82	136	196	294	504	910	1217	172	252	379	639	1048	1454	315	480	822	1184	1657	90
95	18	34	47	75	124	172	267	456	825	1099	159	227	335	585	893	1322	294	443	754	1048	1505	95
100	16	30	44	72	115	156	247	423	754	1015	142	203	291	528	876	1177	271	402	687	947	1353	100
105	...	...	...	...	...	...	...	...	...	...	125	179	245	485	783	1015	247	365	622	859	1228	105